

# Bigger, Stronger, Lighter



## TP 175 PTO

RELIABLE  
WOOD CHIPPING

DESIGNED

MANUFACTURED

DENMARK

3  
YEAR  
WARRANTY  
AS A STANDARD  
TP  
RELIABLE  
CHIPPING

TP 175 PTO is the obvious choice for landscaping and tree care maintenance. The low weight makes the machine operable for tractors from 40 hp.



## New standards for PTO Wood Chippers

- Produced in high strength steel that is 50 % stronger than conventional steel. Result: a stronger and lighter machine
- New blade gauge enables an infeed that is 20 % faster - for utmost capacity
- Due to the TP OPTICUT™ blade system, TP 175 PTO produces a very uniform wood chip quality, that you can size adjust from 4 to 12 mm - very well suited for heating purposes
- To prevent overload of the tractor, the stress control system TP PILOT™ is recommended
- Adaptable for various tractor types, incl. front mounting







A TP SERVICEBOX with critical wear parts comes as an option



# TP 175 PTO

## Technical Data

Max. wood diameter	175 mm
Infeed opening	H x W = 175 x 220 mm
Chipping principle	Disc chipper with TP OPTICUT™
In feed angle	Parallel to driving direction
Feed rollers	2 horizontal
Rotor disc diameter	660 mm
Rotor disc weight	87 kg
Number of blades	4 (2 cuts per round)
Counter steel	1 horizontal og 2 vertical
Chip length	4 - 12 mm
Effect need min.-max.	40 - 90 hp
PTO rotations per minute	1000 rpm (540 rpm with a speedup gear)
Capacity	Up to 20 m <sup>3</sup> /h
Weight	523 kg
Dimensions H x W x L	2429 x 1260 x 2370 mm



**TP OPTICUT™:** The divided blade system ensures that there is always a blade engaging the wood. The result is less vibration, a more steady strain on the machine, lower fuel consumption level and a more uniform wood chip quality.



**TP PILOT™:** The main purpose of the stress control system is to prevent the tractor from overloading. Likewise, the system enables monitoring of the speed of rotor disc and feed rollers. The system also includes an hour meter.

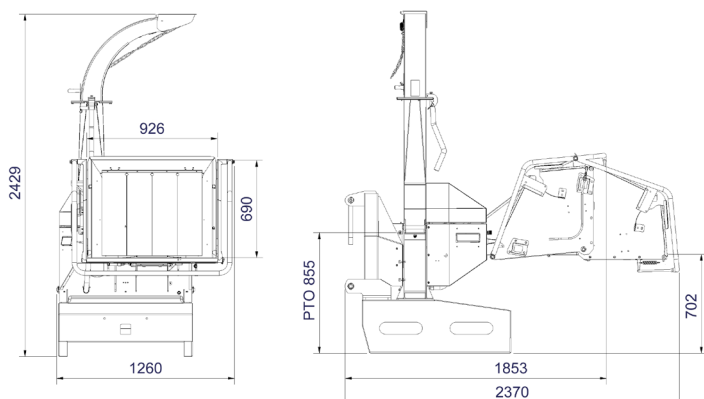

**Linddana A/S**

T +45 75 80 52 00

tp@linddana.com

www.linddana.com

