

The Arborist must-have



TP 215 MOBILE

RELIABLE
WOOD CHIPPING

DESIGNED

+

MANUFACTURED

↓

DENMARK



+

Designed with flexibility, efficiency and versatility in mind, this 8.5" wood chipper appeals to the tasks of any arborist or tree surgeon. The machine built of high strength steel has a total weight below 1400 kg.



Bigger, stronger, lighter

- TP DUAL TORQUE INFEED™ Maximum oil pressure and flow to each feed roller motor! Unsurpassed infeed force, easy infeed of branched material and maximum capacity
- High tech diesel engine with direct injection, easy cold start, high torque reserve and low fuel consumption
- Multi adjustable ejector spout with ejection of woodchips in many heights – Low transport and parking height (<2 m)
- Available in versions with or without turntable
- Patented automatic clutch system between engine and chipper giving less stress on the engine during start-up
- 3 year product warranty





Optimise your up-time with the TP SERVICEBOX
with critical wear parts (included)

TP 215 MOBILE

Technical data

Max. wood diameter	216 mm (8.5")
Infeed opening	H x W = 216 x 265 mm
Chipping principle	Disc chipper with TP TWINDISC™
In feed angle	Parallel to driving direction (turntable is optional)
Feed rollers	2 horizontal
Rotor disc diameter	760 mm
Rotor disc weight	140 kg
Number of blades	4 TP OPTICUT™ blades
Counter steel	1 horizontal and 2 vertical
Chip length	Up to 14 mm
Engine	Kohler/Lombardini KDI 2504 M
Engine power	49 hp (diesel)
Capacity	Up to 20 m³/hour
Weight	1355 kg (single axle version)
Dimensions	Depend on version - see sketch



TP STARTER: Start-up can't be easier. Just turn the key and press the start button - you have started. The no-stress control **TP PILOT™** is the means to a smooth operation that prevents engine overload and allows you to read off disc rpm, working hours etc.

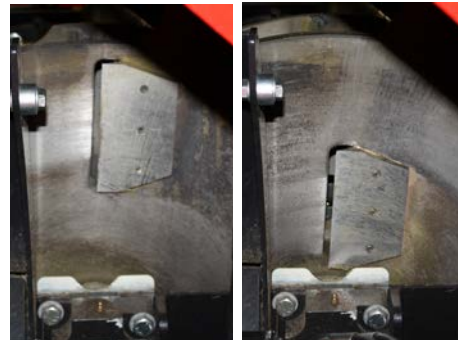

The 4 TP OPTICUT™ blades are placed alternately on the inner and outer part of the disc. This way, a blade is always engaging the wood, causing fewer vibrations, lower fuel consumption and a uniform wood chip.

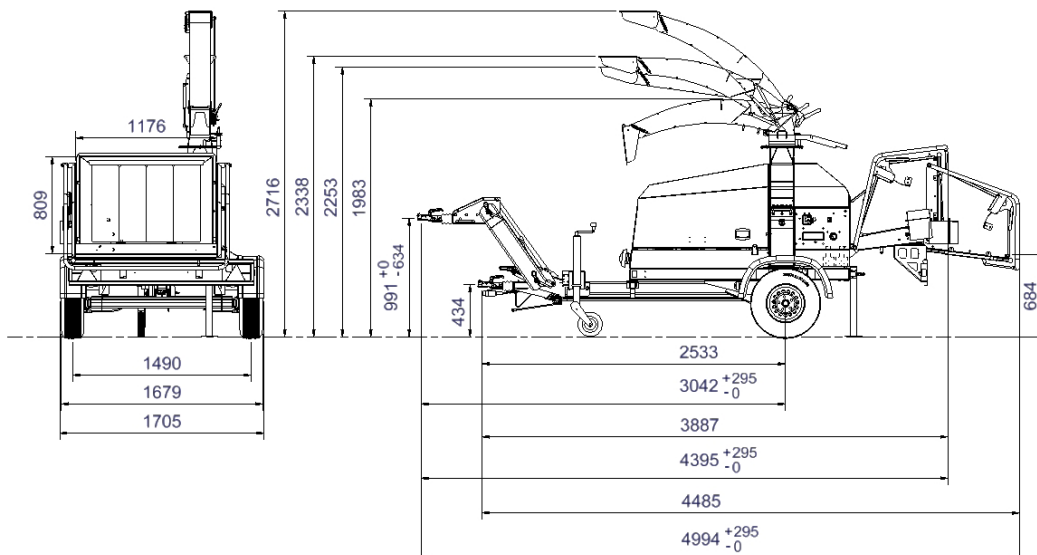

Linddana A/S
T +45 75 80 52 00
tp@linddana.com
www.linddana.com

