



RELIABLE  
CHIPPING



## TP 215 MOBILE



### Infeed section

<b>Hydraulic system:</b>	Integrated
<b>Operation:</b>	Foldable funnel with yellow safety bar (forward/return/stop of feed rollers)
<b>Tip up funnel:</b>	Yes
<b>Infeed opening, height:</b>	216 mm
<b>Infeed opening, width:</b>	265 mm
<b>Funnel opening, height (inside measure):</b>	809 mm
<b>Funnel opening, width (inside measure):</b>	1176 mm
<b>Infeed position:</b>	Parallel with driving direction (turntable optional)
<b>Feed rollers:</b>	2
<b>Feed roller position:</b>	Horizontal
<b>Feed roller diameter:</b>	204 mm
<b>Feed roller pretension:</b>	2 springs 8 mm
<b>Feed roller drive:</b>	xx
<b>Hydraulic oil capacity:</b>	25 litres
<b>Infeed speed (maximum):</b>	36,9 m/min
<b>Hydraulic pump:</b>	xx
<b>Bio-degradable hydraulic oil:</b>	Optional

### Chipping system

<b>Chipping principle:</b>	Disc chipper
<b>Chipping angle:</b>	90 degrees
<b>TP OPTICUT:</b>	Yes
<b>TP TWIN DISC:</b>	Yes

<b>Number of blades/knives:</b>	4
<b>Cuts per round:</b>	2
<b>Blade/Knive gauge - minimum:</b>	14 mm
<b>Blade/Knive gauge - maximum:</b>	14 mm
<b>Rotor speed:</b>	1320 rpm
<b>Rotor diameter:</b>	760 mm
<b>Rotor weight:</b>	140 kg
<b>Transmission:</b>	Belt drive
<b>Anvil/counter knife - horizontal:</b>	1 turnable
<b>Anvil/counter knife - vertical:</b>	2
<b>Replaceable tub plate:</b>	Yes
<b>TP CHIP KIT:</b>	Optional
<b>Tub plate:</b>	Yes

## Trailer

<b>Drawbar make:</b>	ALKO
<b>Height adjustable drawbar:</b>	Optional
<b>Axle make:</b>	ALKO
<b>Number of axles:</b>	1
<b>Max. axle load (total):</b>	1500 kg
<b>Overrunning brake system:</b>	Yes
<b>Tyre size:</b>	185/70 R13C
<b>Max speed:</b>	140 km/h

## Trailer - tandem

<b>Chipping unit on turntable:</b>	Yes
<b>Number of axles:</b>	2
<b>Drawbar make:</b>	ALKO
<b>Height adjustable drawbar:</b>	Optional
<b>Max. axle load (total):</b>	2000 kg
<b>Overrunning brake system:</b>	Yes
<b>Tyre size:</b>	195/50 R13C
<b>Max speed:</b>	140 km/h

## Engine

<b>Make/Model:</b>	Kohler/Lombardini KDI 2504 M
<b>Power, gross:</b>	49 hp
<b>Engine speed:</b>	2600 rpm
<b>Power, gross (kW):</b>	36 kW
<b>Cooling type:</b>	Water
<b>Fuel type:</b>	Diesel
<b>Number of cylinders:</b>	4
<b>Tank size:</b>	52 litres
<b>Fuel consumption (average):</b>	4 l/h
<b>Hour meter:</b>	Yes
<b>Clutch system:</b>	TP STARTER

## Discharge system

<b>Standard discharge spout:</b>	Turnable
<b>Rotation of discharge spout:</b>	270 degrees
<b>TP VARIO SPOUT:</b>	Optional

## No-stress control

<b>No-stress control:</b>	TP PILOT
---------------------------	----------

Displays feed roller rotations:	Yes
Displays rotor rotations:	Yes
Timer for work hours (can be reset):	Yes
Timer for total work hours:	Yes

## Accessories/Upgrades

Spare wheel:	yes
TP CHIP KIT:	yes
Bio oil:	yes

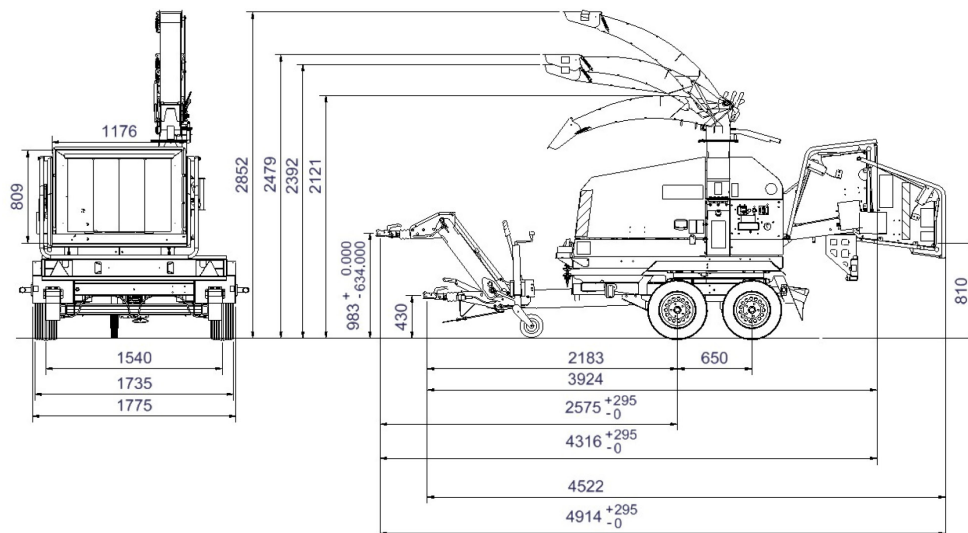
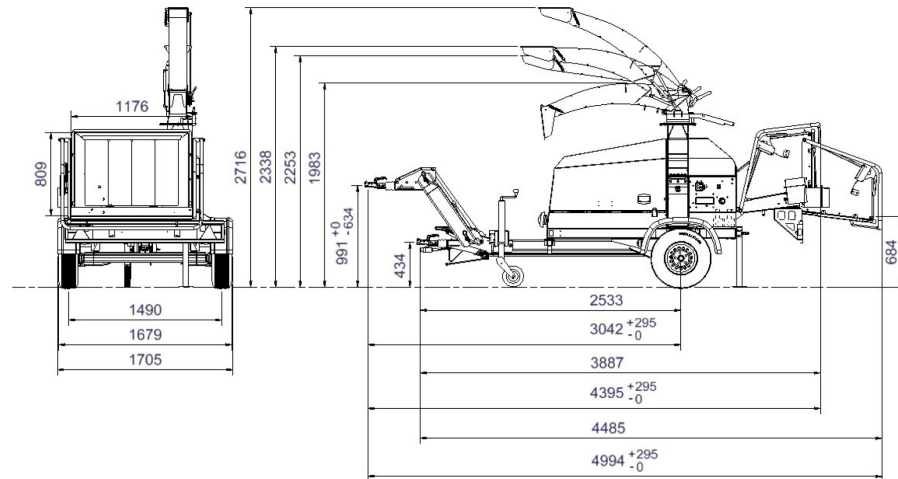

IRISH GRASS MACHINERY LTD,  
 39 ROSEMOUNT BUSINESS PARK,  
 BALLYCOOLIN,  
 DUBLIN D11 RW61.  
 00353 1 899 1212  
 sales@irishgrassmachinery.ie