

Verti-Drain[®] 2519

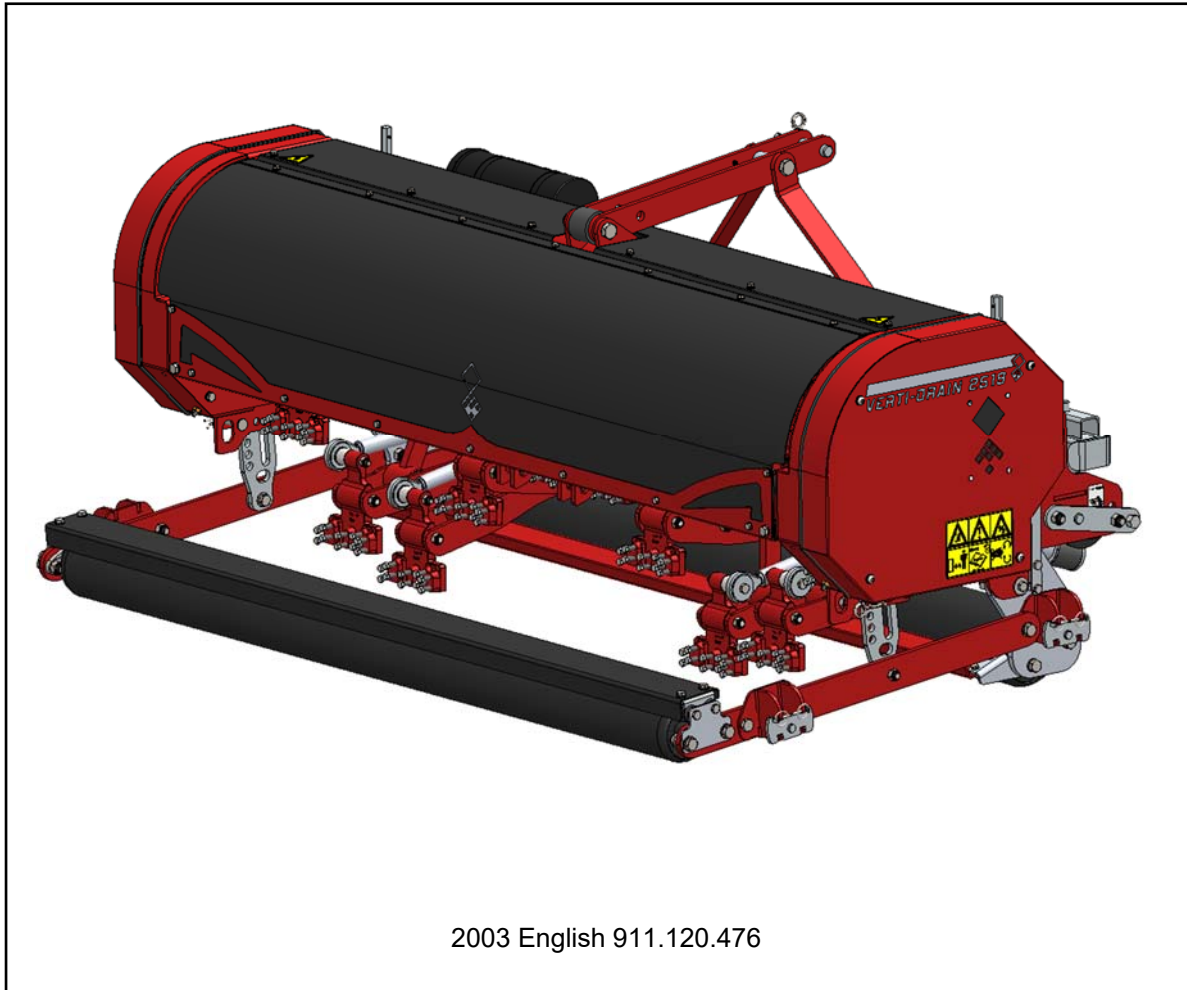

Translation of the original User Manual
From serial number H2192203

REDEXIM

Kwekerijweg 8

3709JA – Zeist – The Netherlands

Tel.: +31 (0)306 933 227

E-mail: redexim@redexim.com

Internet: www.redexim.com

EU DECLARATION



We – **Redexim BV, Utrechtseweg 127, 3702 AC Zeist, Holland** – declare entirely under our own responsibility that the product:

VERTI-DRAIN® 2519 WITH A MACHINE NUMBER AS INDICATED ON THE MACHINE AND INDICATED IN THIS MANUAL

to which this declaration refers, complies with stipulation of the 2006/42/EC machine directive and with the norms NEN-EN-ISO 12100:2010, NEN-EN-ISO 13857:2008, NEN-EN-ISO 4254-1:2013 and NEN-EN-ISO 4254-5:2018.

Zeist, 31.01.20



A.C. Bos
Manager Operations & Logistics
Redexim Holland

FOREWORD

Congratulations on your Verti-Drain® 2519 purchase. For safe and long-lasting operation of this machine, it is necessary to read and to understand this user manual. It is impossible to work safely with this machine *without* complete knowledge of the content of the user manual.

This machine does *not* operate independently! It is the user's responsibility to use the correct tractor or other towing vehicle. The user should check the combination of the towing vehicle and the machine with regard to various aspects, such as noise level and safety risks. In addition, the user should comply with the user instructions of the vehicle and spare parts that are used.

All information and technical specifications provided at the moment that this document is published are the most recent ones. Design specifications may be changed without prior notice.

You can contact your sales point or dealer if you have questions and/or if there are ambiguities in this manual or about the machine concerned.

This document is a translation of the original user manual.
Upon request, the original user manual is available in Dutch.

WARRANTY CONDITIONS

AT THE TIME OF DELIVERY THIS MACHINE IS GUARANTEED AGAINST MATERIAL DEFECTS.
THIS WARRANTY IS VALID FOR A PERIOD OF 12 MONTHS FROM THE PURCHASE DATE.
REDEXIM WARRANTIES ARE SUBJECT TO THE 'GENERAL CONDITIONS FOR SUPPLY OF PLANT AND MACHINERY FOR EXPORT, NUMBER 188' THAT ARE PUBLISHED UNDER THE AUSPICES OF THE UNITED NATIONS ECONOMIC COMMISSION FOR EUROPE.

REGISTRATION CARD

For your own information, fill in the table below:

Serial number of the machine	
Dealer name	
Date of purchase	
Remarks	

TABLE OF CONTENTS

1.	SAFETY INSTRUCTIONS	5
1.1	Obligations of the user	5
1.2	Maintenance, repairs and adjustments	6
1.3	Using the machine	6
2.	TECHNICAL DATA	7
3.	GENERAL DESCRIPTION	7
4.	SAFETY STICKERS	8
5.	FIRST INSTALLATION	9
6.	THE PTO AXLE.....	10
6.1	Length of the PTO axle	10
6.2	Using the PTO axle	11
6.3	Slip coupling: Information and maintenance	11
7.	ATTACHING AND DETACHING THE MACHINE	12
7.1	Attaching the machine	12
7.2	Detaching the machine	13
8.	TRANSPORT	14
9.	PUTTING THE MACHINE INTO OPERATION.....	14
9.1	Safety.....	14
9.2	Working speed	15
9.3	Start/Stop procedure	16
10.	TECHNICAL INFORMATION	17
10.1	Adjusting the working depth	17
10.2	Pin angle adjustment	18
11.	OPTIONS.....	19
11.1	Peat hold-down kit.....	19
11.2	Windrow kit	20
11.3	Pins	20
12.	MAINTENANCE	23
12.1	Maintenance schedule	23
12.2	Cleaning	24
12.3	Lubrication points	24
12.4	Adjusting the shock absorber	25
12.5	Checking the oil level in the gearbox	25
12.6	Crankshaft	26
12.7	Replacing a crank / Crank bearing	27
12.8	Eliminating crankshaft tensions.....	27
12.9	Timing and tightening moments.....	27
12.10	Mounting and dismounting the taper-lock clamping bush	29
12.11	Adjusting the tension of the v-belts.....	30
13.	TROUBLE SHOOTING (PROBLEM ANALYSIS)	31



1. SAFETY INSTRUCTIONS

This machine is designed for safe use. This can only be achieved if you completely follow the safety instructions described in this manual.

Read and understand the manual *before* you start using this machine.

If the machine is not used as described in this manual, this can result in injuries and/or damage to the machine.

This user manual lists instructions that are numbered in sequence. You should follow this sequence. A

 is an indication of a safety instruction. A  means a tip and/or note.

1.1 Obligations of the user

The machine is solely intended for work on grass fields or areas where grass can grow. Any other use is improper. The manufacturer will not accept any liability for damage resulting from improper use. All risks occurring with this are entirely at the expense of the user.

All persons assigned to operate, maintain and repair the **machine** by the owner must completely read and understand the operation manual and in particular the chapter of **Safety Instructions**.

Modifications to the machine that have a negative impact on the safety must be rectified immediately.

The user is obliged to check the machine for visible damage and defects before using the machine.

For safety reasons it is not permitted to make changes or adjustments to the machine (except those approved by the manufacturer). If modifications to the machine have been made, then the current CE marking is cancelled. The person that has made these modifications has to apply for a new CE marking himself.

Following the use, maintenance and repair instructions prescribed by the manufacturer is also considered proper use of this machine.

The user is responsible for the safe combination of the machine and the towing vehicle, which comply with the requirements as described in the Technical Data (**see Chapter 2**). **This entire combination should be tested** for noise, safety, risk and user friendliness. User instructions should also be drafted.

Dress appropriately during work activities with the machine. Wear sturdy shoes with steel toecaps, long trousers and tie up long hair. Do not wear loose clothing.

The general applicable health & safety (Dutch: ARBO) regulations must also be followed in addition to the instructions in this user manual.

Relevant traffic regulations also apply in case of using public roads.

1.2 Maintenance, repairs and adjustments

Keep a record of the repair activities.

When unskilled people use, maintain or repair the machine, this could result in injuries to the user *and* to third parties. This should be avoided!

Use only original Redexim parts for maintenance or repairs because of the safety of the machine *and* of the user.

Only authorised technical personnel may carry out repairs to the machine.

When carrying out maintenance, adjustments and repairs, it is necessary to block the machine in order to prevent it from sinking away, driving off and/or sliding off.

If a hydraulic installation is present, you should **always** make it pressure-free *before* working on this installation.

Used oil / grease is harmful to the environment. Dispose of these substances according to the regulations that apply in your location.

1.3 Using the machine

Attach the machine to the towing vehicle according to the regulations. Pay close attention to the risk of injury!

Never use the machine in the absence of protective guards and safety stickers.

Check the machine for loose bolts, nuts and components *before* every operation.

Check whether you have a clear field of vision – both close by and far away – *before* you start moving.

All persons that are going to operate the machine must be familiar with all the functions and control elements of the machine *before* starting any work activities.

NEVER crawl under the machine! If necessary, tip over the machine to work at the bottom side.

If present, check the hydraulic hoses regularly and replace these when the hydraulic hoses are damaged or appear old.

2. TECHNICAL DATA

Type	2519
Working width	1.95 m (76.7")
Working depth	Up to 250 mm (10")
Driving speed (Theoretically at 540 rpm of the PTO) Hole distance 65 mm (2½") Hole distance 100 mm (3.9") Hole distance 165 mm (6½")	Up to 1.79 km/h (1.1 mph) Up to 2.75 km/h (1.71 mph) Up to 4.53 km/h (2.81 mph)
Maximum PTO rpm:	Maximum 540 rpm
Weight	900 kg (1984 lbs)
Distance of the holes between the pins	100 mm (4") @ 18 mm (¾") holes 65 mm (2.5") @ 12 mm (½") holes
Distance between the holes in the driving direction	25 – 165 mm (1" - 6½")
Pin angle adjustment	90°-75°
Recommended tractor	Minimum 60 hp with a minimum lifting capacity of 920 kg (2028.25 lbs) at 610 mm (24") behind the lifting eyes
Capacity (Theoretical maximum) Distance between the holes 65 mm (2½") Distance between the holes 100 mm (3.9") Distance between the holes 165 mm (6½")	Up to 3,490 m ² /hour (37,566 ft ² /hour) Up to 5,362 m ² /hour (57,716 ft ² /hour) Up to 8,833 m ² /hour (95,077 ft ² /hour)
Dimensions (length x width x height)	1,250 x 2,314 x 963 mm (49.2" x 91.1" x 37.9")
Maximum pin dimension	Solid 18 x 250 mm (¾" x 4") Hollow 25 x 250 mm (1" x 10")
Slip coupling setting	Standard 550Nm (4,868 lbf.inch) Maximum setting 700 Nm (6,195 lbf.inch)
Gearbox oil	80W90 GL5 – 1.2 litres (0.31 gallon)
3-point connection	CAT 1/2
Standard components	Set of solid pins 12/250 (½"x10") PTO with slip coupling
Optional	Hollow pins Peat hold-down fingers Windrow kit

3. GENERAL DESCRIPTION

The Verti-Drain® 2519 is a machine for aerating grass fields.

The Verti-Drain® 2519 is a 3-point machine. You will need a tractor in order to use the Verti-Drain® 2519.

4. SAFETY STICKERS

Safety stickers are located on both sides of the machine. These safety stickers must always be clearly visible and legible and must be replaced if they have become damaged (see Figure 1).

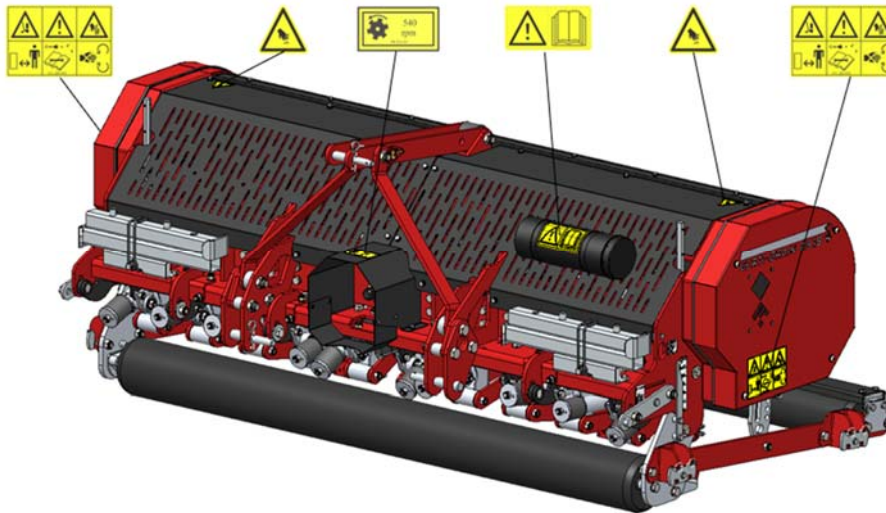



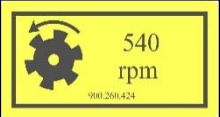

Figure 1

 <p>911.280.402</p>	<ul style="list-style-type: none"> - In case of maintenance, adjustments and repair, always switch OFF the engine of the towing vehicle and the PTO. Prevent the combination from driving and/or sliding away. - Keep a distance of minimum 4 metres if the machine is operating (except the operator sitting in the towing vehicle). - During operation, NO persons are allowed within the danger zone of the machine, because there is danger of physical injuries caused by moving components.
 <p>900.280.402</p>	<ul style="list-style-type: none"> - Prior to using the machine, the operators of the machine must read the user manual carefully.
 <p>900.280.404</p>	<ul style="list-style-type: none"> - BE CAREFUL not to get any parts of your body jammed when opening the rear cover!
 <p>900.260.424</p>	<ul style="list-style-type: none"> - You can operate the machine safely, if the PTO does not exceed 540 rpm.

5. FIRST INSTALLATION

The machine should be prepared for use as follows (see Figure 2):

- ⚠ **Make sure that the cable / crane / lift can hoist minimum 2,000 kg (4409 lbs).**
- 1. Attach a cable to the lifting eye (1).
- ⚠ **!! Keep a safe distance. The machine turns / slides away during hoisting / lifting !!**
- ⚠ **!! Never crawl under the machine !!**
- 2. Carefully lift the machine including the pallet. Pallet and machine are now tilted and this may cause the machine to slide away suddenly.
- 3. Support the pallet, remove the 3-point pin (2) and carefully turn the pallet towards the ground.
- 4. Loosen the pallet (4) by removing the 3-point pins (3).
- 5. Lift the machine and off the pallet.
- 6. Carefully lower the machine until it stands safely on the ground.
- 7. Unscrew the bolts (5) and open the rear cover.
- 8. Replace the plug in the gearbox with the de-aerator (6) that is added to the toolbox (7).
- 9. Close the rear cover and screw the bolts (5) tightly.

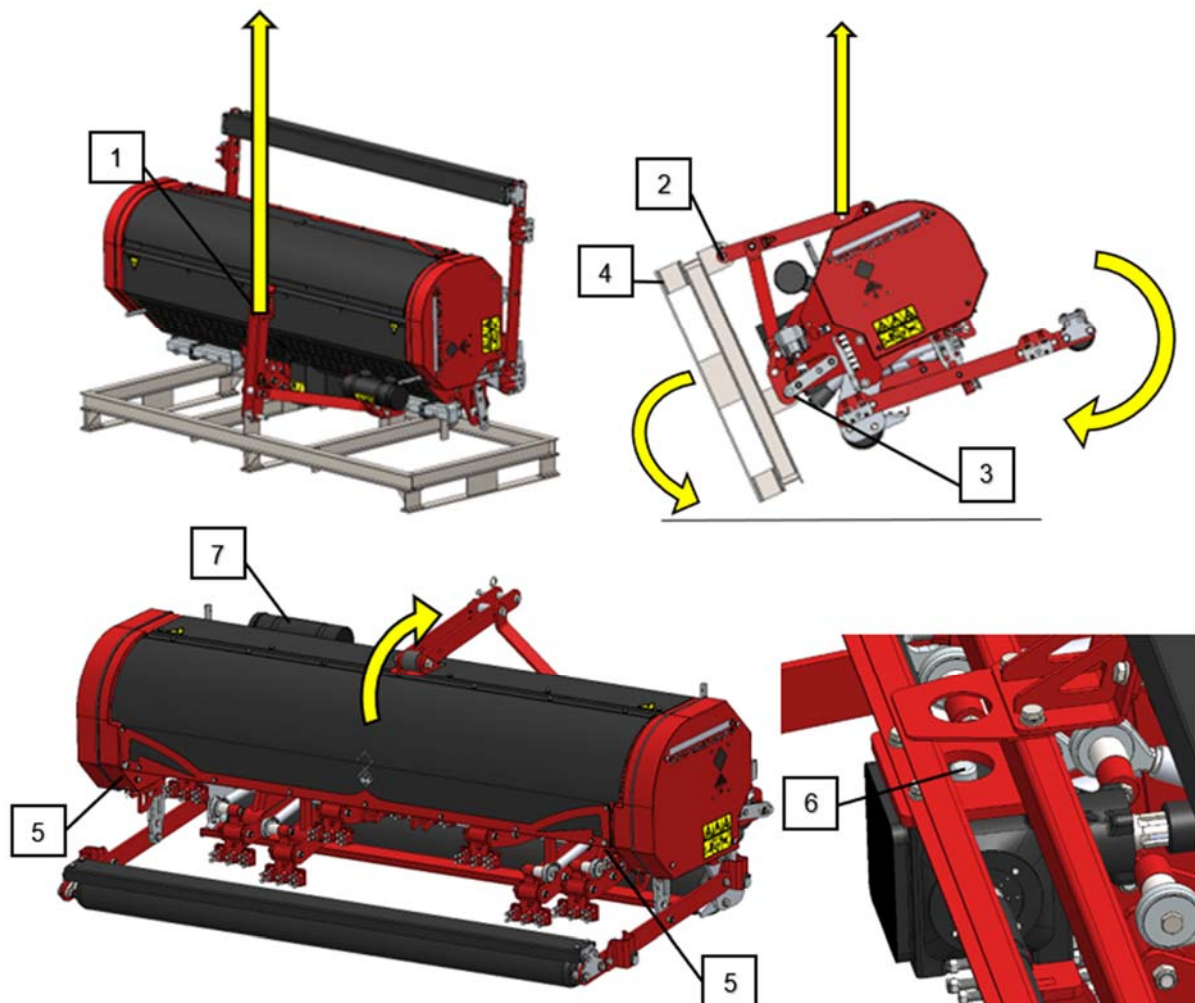

Figure 2

6. THE PTO AXLE

The PTO axle is a very important component that takes care of the drive from the tractor to the machine. The PTO axle ensures safe use of the machine on condition that it is properly installed and maintained. The PTO has its own CE certification and manual. These are delivered together with the PTO axle.

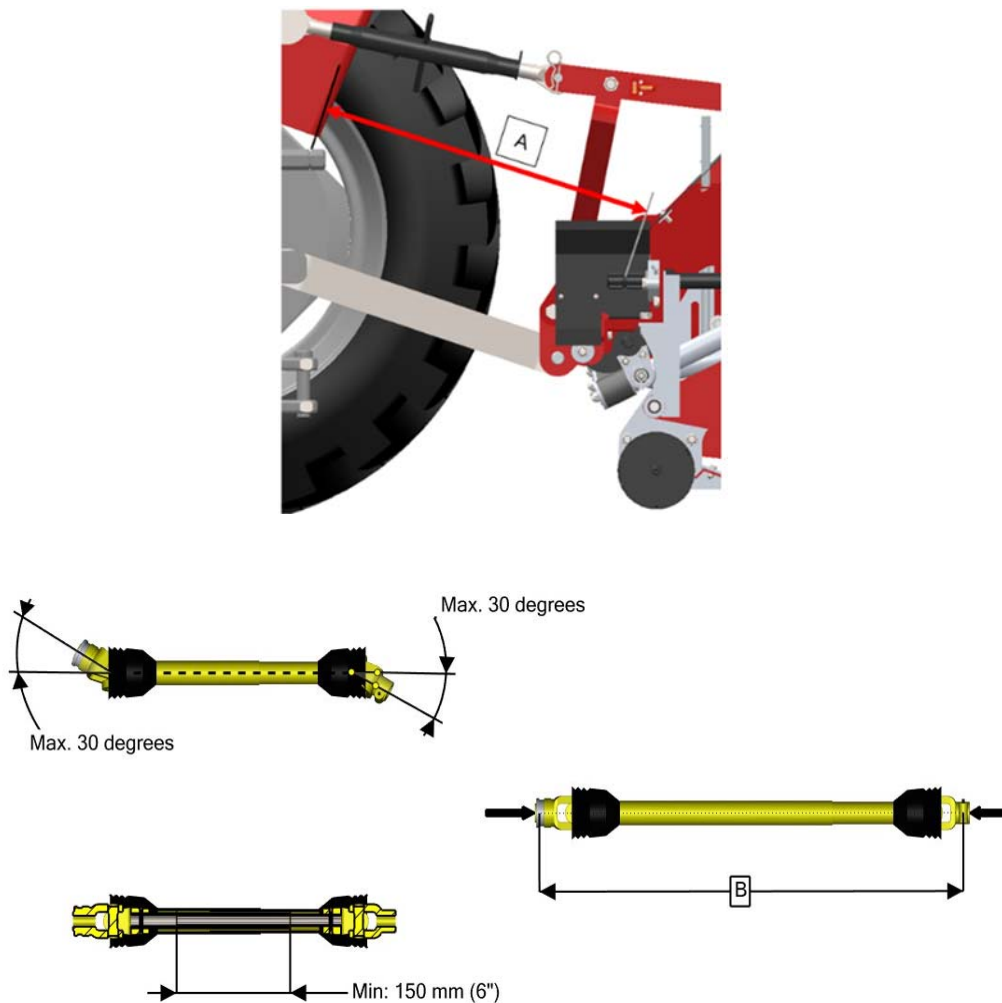



Figure 3

6.1 Length of the PTO axle

The length of the PTO axle is very important. If it is too long, it can damage the drive of the tractor and/or the machine. If the overlapping length of the cylinders becomes less than 150 mm (6") at any time, it can damage the PTO axle. The required length changes when the machine is lifted or when a different tractor is used! If a new machine is purchased or if another towing vehicle is used, the length of the PTO axle should be checked and shortened, if necessary (see Figure 3).

1. Measure the distance 'A' (from groove to groove) between the tractor's PTO and the machine's connection point, when the machine is horizontal on the ground and the tractor is attached.

2. Measure the distance 'B' of the PTO axle in its shortest position from the locking pin to the locking bolt.
3. Divide the PTO axle in two parts and remove the protection cap at both ends.
4. The ends of the cylinders *and* the protection caps should be shortened: $(B-A) + 75 \text{ mm (3")}$.
5. Smooth off all components and then assemble all components. For this purpose, use lubrication grease.
6. Mount the PTO axle including the slip coupling at the machine side.
7. Attach the other end of the PTO axle to the tractor.
8. Check the overlap of the cylinders.

 **Never use the machine if it has a damaged PTO protection cap. First replace the protection cap.**

6.2 Using the PTO axle

The following items must be checked for correct use of the PTO axle:

1. The angle of the rotation points should always be smaller or equal to 30 degrees during work activities.
2. The PTO axle of the tractor must be parallel to the PTO axle of the machine.
3. The overlap of the cylinders must always be minimum 150 mm.
4. Never use the machine if it has a damaged PTO protection cap.
5. See the PTO manual for information about lubrication.

6.3 Slip coupling: Information and maintenance

If used and maintained correctly, the slip coupling will protect your machine against damage. The following data are important for adjusting the slip coupling (see Figure 4).

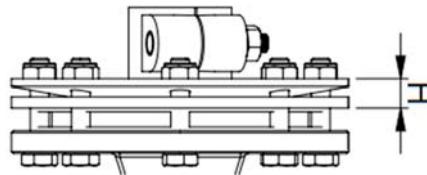



Figure 4

1. The depressed length H of the cup spring is standard set at 15 mm (0.59") (550 Nm (4,868 lbf.inch)).
2. When the slip coupling slips, the bolts and nuts may be tightened gradually, until the minimum length of 14.4 mm (0.57") of the cup spring is achieved (700 Nm (6,195 lbf.inch)). Additional compression will overload the machine.

 **Screwing the bolts / nuts too tight could ultimately damage the machine or create unsafe situations.**

 **!! If the slip coupling starts to operate, you should switch off the PTO, lift the machine off the ground, and repeat the start procedure.**

7. ATTACHING AND DETACHING THE MACHINE

Attaching and detaching the machine has to be done carefully. Follow the instructions below:

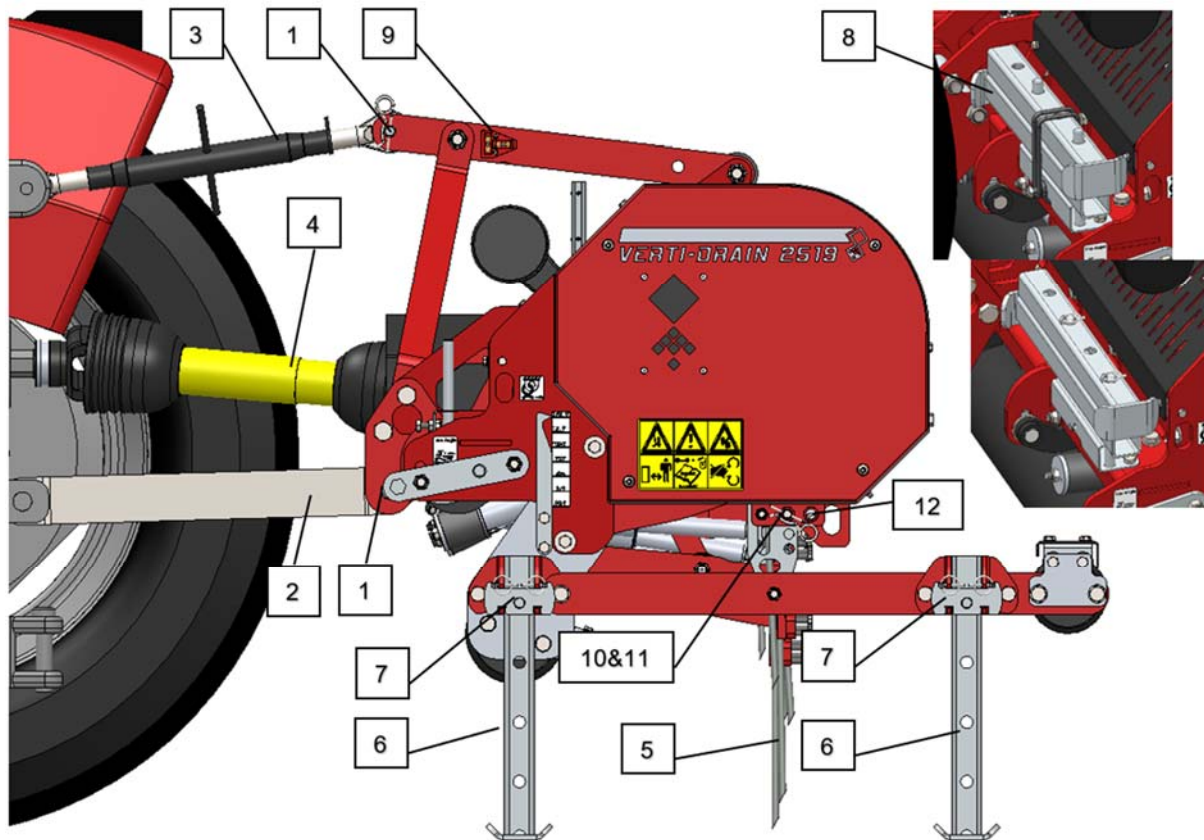

Figure 5

7.1 Attaching the machine

Prior to attaching the machine, check the following points:

- Check whether the machine is undamaged and whether it is safe to attach and use the machine.
- Controleer of bouten en moeren met het juiste moment zijn aangehaald.
- Check whether all safety stickers are on the machine and whether these are undamaged and easily readable. **Never** use the machine if it has damaged or unreadable stickers.

The machine should be attached to the tractor in the following manner: (see Figure 5)

1. Remove the 3-point pins **(1)** from the machine.
2. Carefully drive the tractor backwards until the lifting arms **(2)** can be attached to the machine.



!! Make sure that the tractor and the machine cannot move while you are attaching them !!



!! Switch off the tractor engine *before* attaching the machine !!

3. Attach the lifting arms **(2)** to the machine using the 3-point pins. Lock the pins using the R-clips.
4. Set the stabilizer of the lifting arms **(2)** to 100 mm lateral stroke.
5. Mount the top rod **(3)** onto the tractor and attach it to the machine.
6. Connect the PTO **(4)** between the machine and the tractor. Slip coupling at the machine side.
7. Place the required pins in the pin holders **(5)**, if these are not mounted yet.



Make sure that the 3-point pins are locked using the R-clips!

8. Start the tractor and lift the machine.



!! Switch off the tractor's engine and PTO before descending !!



!! Make sure that the tractor and machine cannot move uncontrolled !!

9. Remove the adjustable legs **(6)** by removing the pins **(7)** and place them on the machine **(8)**.
Secure the tension rubber or clips.
10. Set the rear roller in the terrain-following position by removing the pin **(10)** and placing this pin in the rear hole **(12)**. Secure using the R-clip.
11. Adjust the top rod so that the machine is at the working depth that you want to use and it is horizontal in relation to the ground. Use a spirit level **(9)** as reference for this work activity.

7.2 Detaching the machine

The machine should be detached in the following manner (see Figure 5):

1. Fix the rear roller by inserting the pin **(10)** into the hole **(11)** in the correct position.
Secure using the R-clip.
Make sure that the rear roller is horizontal, so that the machine is supported straight on the adjustable legs.



Make sure that the machine and the tractor cannot move while you are detaching them!



Switch off the tractor engine *before* detaching the machine!

2. Place the adjustable legs **(6)** and attach them to the machine using the pins **(7)**.
3. Secure the pins using the locking clips.



Check whether the adjustable legs are mounted in the correct holes to prevent damaging the pins and/or machine.

4. Carefully place the machine on the ground.



Check again whether the machine is stable on the ground.

5. Loosen the top rod **(3)** and remove it.
6. Detach the lifting arms **(2)** from the machine.
7. Detach the PTO **(4)** at the tractor side.
8. Start the tractor and drive off.

8. TRANSPORT

The user is responsible for transporting the machine on public roads. Verify the national legislation regarding the regulations. In view of the machine's weight, it is not advised to drive faster than 12 km/h (12.4 mph) with a raised machine. Higher speeds can lead to hazardous situations and result in damage to the machine and tractor.

 **When the machine is raised off the ground, the front axle of the tractor has to support minimum 20% of its weight.**

If the machine is not transported by being towed by the tractor, the machine may be secured / hoisted at the following points (see Figure 6):

- 1: Hoisting point for hoisting the machine
- 2: Securing points positioned at both sides of the machine

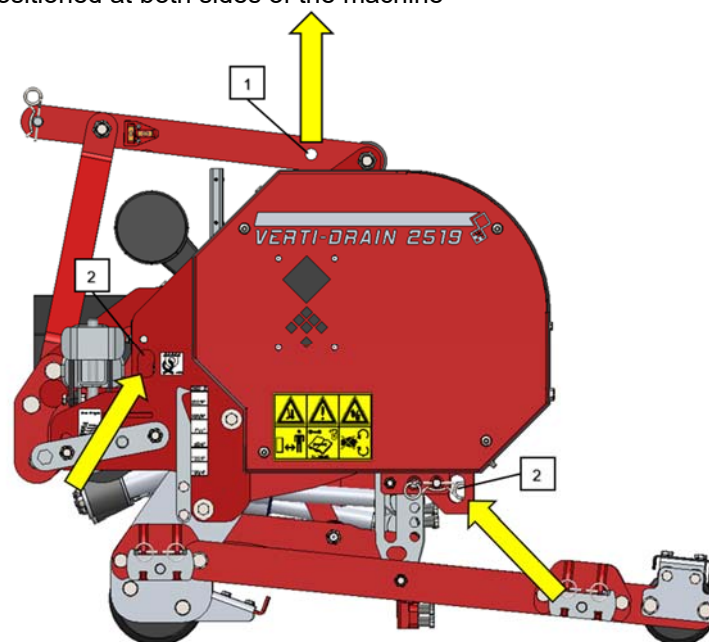

Figure 6

9. PUTTING THE MACHINE INTO OPERATION

9.1 Safety

Before using the machine, you should check the following:

1. Are there loose objects in the field? First remove these objects.
2. Are there slopes? The maximum slope is 20 degrees for this machine. Always go from top to bottom.
3. Are there cables / pipes buried in the ground? If so, determine their depth and adjust the working depth of the machine to 60% of the depth of the cables / pipes.
4. Are there hard objects in the ground? If so, use the Verti-Drain® 2519 with an adjusted speed and adjust the working depth.

5. Is there danger of flying objects (e.g., golf balls) that distract the attention of the driver? If so, the Verti-Drain® 2519 **CANNOT** be used.
6. Is there danger of sinking / sliding away? If so, postpone using the Verti-Drain® 2519.
7. If the soil is frozen or very wet, postpone the activities until conditions improve.
8. If the soil is very compressed, use shorter pins or adjust the working depth.
9. Do NOT make sharp curves when the machine touches the ground.

9.2 Working speed

The maximum safe working speed of the machine is approx. 4.53 km/h (2.81 mph). However, the user should check which speed is optimal to achieve the required result per individual situation and soil treatment.

The driving speed and the rpm of the PTO determine the distance between the holes in the driving direction. If the client requires a small distance between the holes, you have to drive slower which depends on the possibility to reduce the tractor speed.

Table 1 shows the appropriate driving speed to obtain the required distance between the holes at maximum 540 rpm of the PTO.



If you expect hard objects, you must reduce the speed.



The pin holders can start floating in case of using heavier pins, other applications or maximum pin angle. Reduce the rpm *before* the pin holders are forced upwards and damage the machine.



If the Verti-Drain is incorrectly attached to the tractor, the different PTO angles can cause vibrations in the driveline of the machine. These vibrations can damage the machine and distort the holes in the ground. See Chapters 6 and 7 for the correct settings.



If the PTO is shortened incorrectly or if another tractor is used, the gearbox may be overloaded and cause damage.

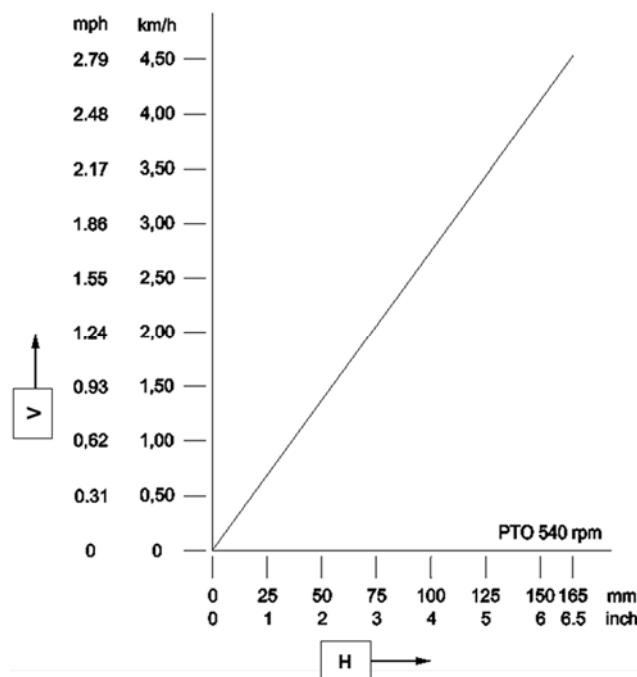

Table 1: Speed (V) versus Distance between the holes (H)

9.3 Start/Stop procedure

The start procedure is **VERY** important. If this procedure is not executed as described below, it might result in serious damage to the machine.

The start procedure is as follows:

1. Check the Verti-Drain® 2519 for loose components and look whether all components function properly.



If loose components are observed or components do not function properly, the problems must be solved *before* using the Verti-Drain® 2519!

2. Drive to the spot where the processing should take place.
3. Lower the machine until the lower pins almost touch the ground.
4. Adjust the tractor engine to around 1200 rpm.
5. Put the tractor in the correct gears and drive forwards.
6. Switch ON the PTO.
7. While it turns, lower the machine carefully into the ground during the forward drive.
8. Increase the PTO's revolutions to the maximum allowed value of 540 rpm.



Always lower the machine CAREFULLY.

During the work activities, the front roller has to be adjusted to the ground in a stable manner. If the machine is unstable, other pins should be mounted *or* the working depth has to be adjusted.



Failing to eliminate the instability will damage the machine. The machine is NOT protected against this continuous overload.



NEVER reverse with the pins in the ground or close to the ground.



Do not use a hydraulic top rod.

Stopping occurs as follows:

1. Reduce the number of engine revolutions.
2. Lift the machine off the ground.
3. Detach the PTO as soon as the pins are out of the ground.
4. Raise the machine further until the pins are minimum 120 mm above the ground.
5. Go to the next location and start again as described above.



It is absolutely necessary to work according the aforementioned procedures. If you place the machine on the ground without a running PTO, you might damage the machine severely.

10. TECHNICAL INFORMATION

Generally speaking, the Verti-Drain® 2519 is not a complicated machine. A number of technical issues will be explained. If you still have questions, please contact your dealer who is always ready to assist you.

10.1 Adjusting the working depth

The working depth can be adjusted, when the machine is lifted before the start of the work.

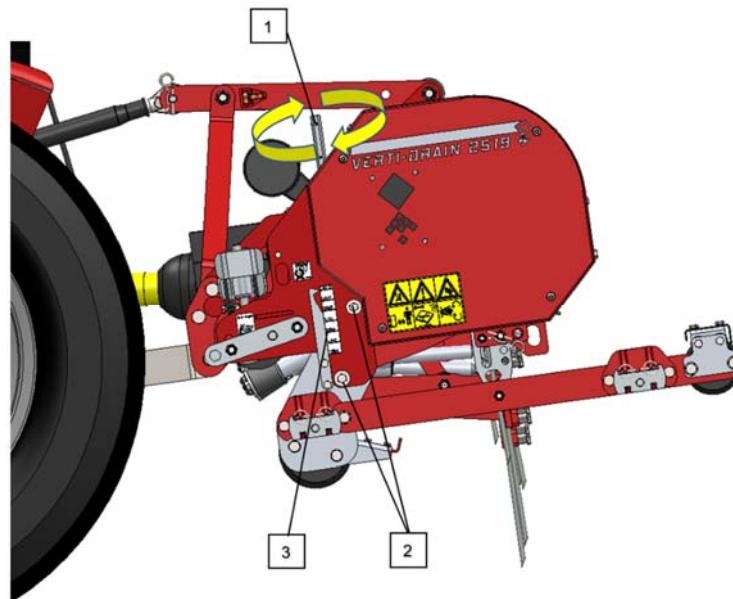

Figure 7

To adjust the working depth (see Figure 7):



!! Switch off the tractor's engine and PTO before descending !!



!! Make sure that the tractor and machine cannot move uncontrolled !!

1. First, loosen with a single turn the nuts (2) of the front roller at both sides of the machine.
2. Rotate the roller to the required working depth using the spindle nuts (1) at both sides of the machine.



Use the ring spanner delivered in the toolbox.

3. Use the indication stickers (3) at both sides of the machine to find the correct working depth.



The depth adjustment on the stickers applies only if one uses pins of 250 mm (10"). If shorter pins are used, deduct the difference in length compared to the 250 mm (10") from the values on the sticker.



Make sure that the same working depth is set at both sides of the machine. Different settings can damage the machine.

4. Tighten the nuts (2) of the front roller.

10.2 Pin angle adjustment

All pins can be adjusted simultaneously to enlarge or reduce the pin angle. You adjust the pin angle as follows (see Figure 8):

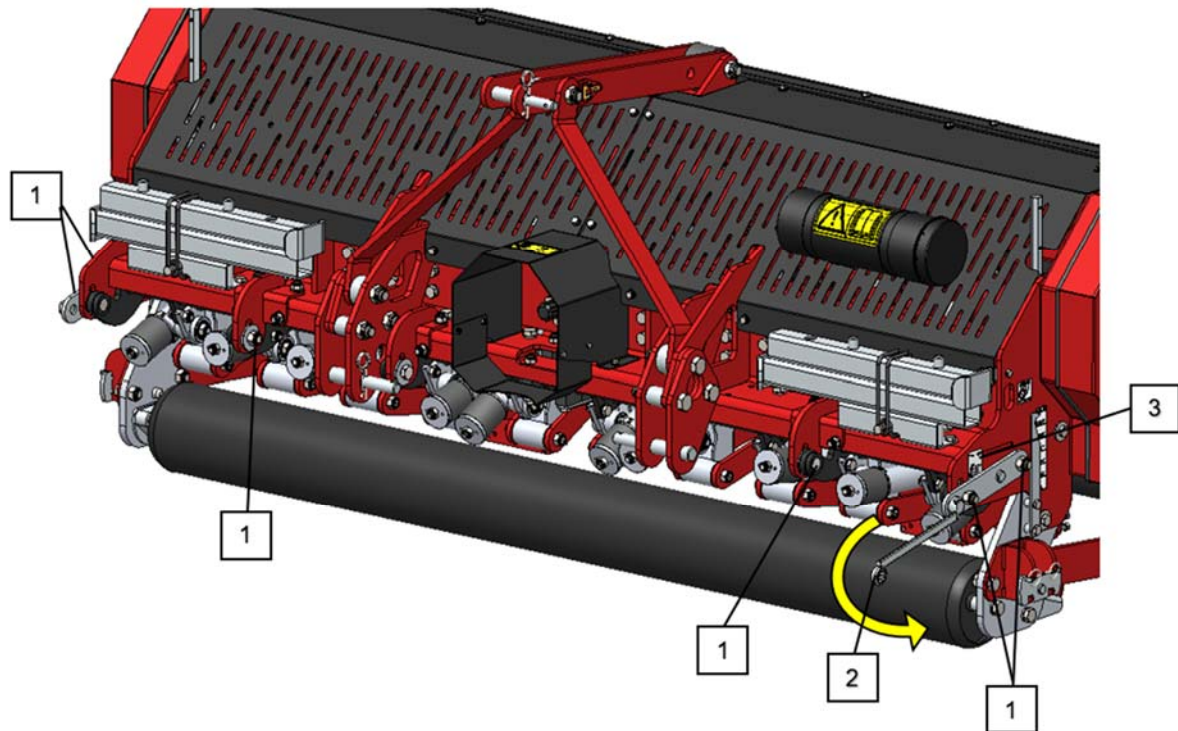

Figure 8



!! Switch off the tractor's engine and PTO before descending !!



!! Make sure that the tractor and machine cannot move uncontrolled !!

1. Loosen with a single turn the nuts (1) of the angle adjustment.
2. Place a ring spanner (2) on the lever and position it in the required pin angle. Read the pin angle in the indication sticker (3).



Use the ring spanner delivered in the toolbox.

3. Tighten the nuts (1) of the angle adjustment.



A 90° angle means hardly any heave movement of the pins. A 90° angle is required for hollow pins and is recommended for pins of 8 mm (5/16") or smaller.



From 90° to 75° means more heave movement of the pins. This adjustment may only be used in combination with solid pins of 12 mm (0.5") and 18 mm (0.7"). Furthermore, this depends on the condition of the ground, the pin size and the requirements of the user.



In case of 90°, the pins go into the ground perpendicularly only if the machine is installed correctly. If this is incorrect, forces may come into play that damage the machine. Adjust the machine horizontally in relation to the ground (see Chapter 7).



Make sure that the same angle is set at both sides of the machine. Different settings can damage the machine.

11. OPTIONS

11.1 Peat hold-down kit

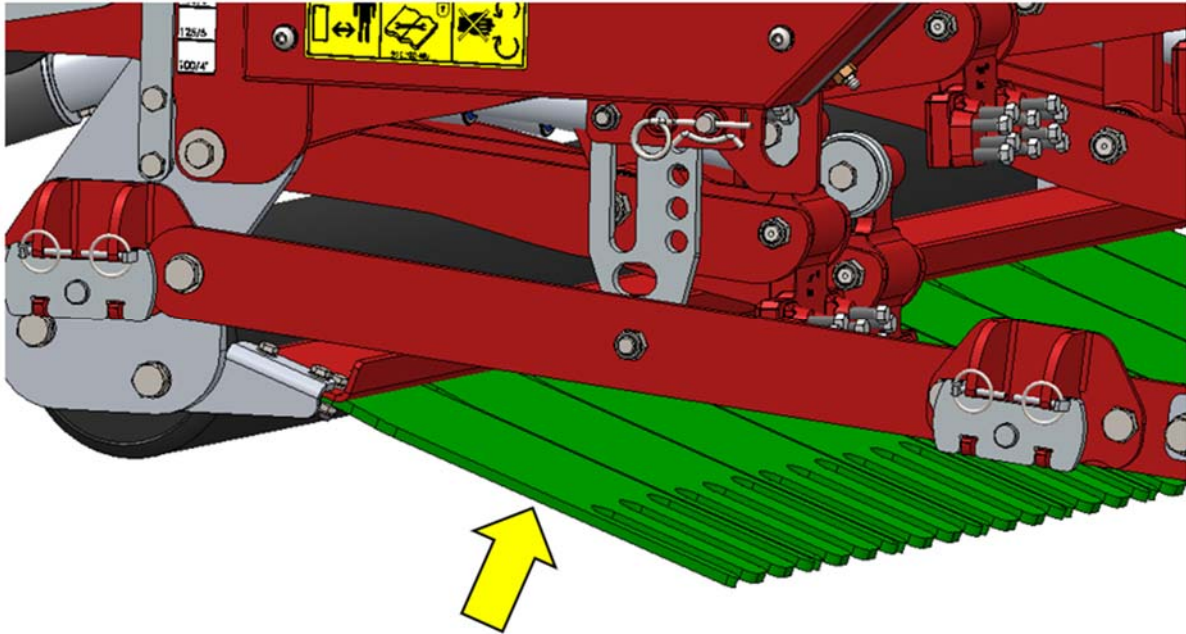

Figure 9

You can use a peat hold-down kit if grass has come loose.

Two types of peat hold-down kits are available for the Verti-Drain® 2519:

- 12 mm (1/2") pins: article number 211.251.902
- 18 mm (3/4") pins: article number 211.251.904

A standard feature of the Verti-Drain® 2519 is a fastening section to which you can attach the peat hold-down fingers.

This kit consists of a set peat hold-down fingers and the fastening material consisting of a number of bolts and nuts.

MOUNTING THE PEAT HOLD-DOWN KIT

- Included in the ordered set are the plates. Attach the plates to the main bar using bolt, rings and nut. Align the plates with the pins via the slotted holes in the plates.
- If the plates are bent in one direction after extensive use, you attach them the other way around.



Check the length of the shock absorber if the pins touch the front side of the hole during work activities (see Section 12.4).



NEVER crawl under the machine! Make sure the machine is firmly blocked!

11.2 Windrow kit

If you work with hollow pins, plugs or cones are removed out of the ground.

The windrow kit takes care of centring the cores in the middle of the work path after the treatment. Afterwards, the cores can easily be removed.

The windrow kit is available under article number 211.251.908 (see Figure 10).

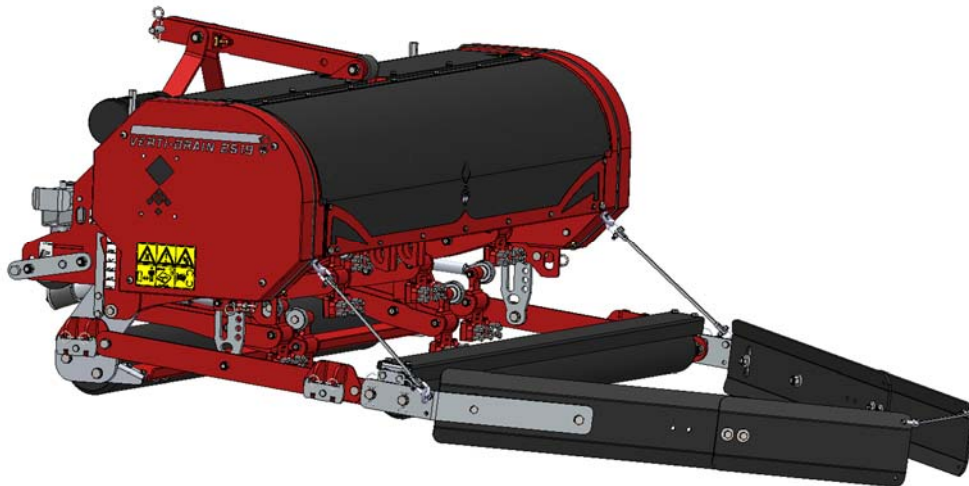

Figure 10

11.3 Pins

Different types of pins are available for this machine.

Generally speaking, the pins can be divided into two categories: solid and hollow pins.

The next page details the differences in operation between the solid and hollow pins.

Each category consists of various diameters and lengths. See the Parts page for a complete overview.

We recommend using only original Redexim pins, because these are developed for the best result and wear resistance,

The locking bolts (A) may be tightened with a torque of 40 Nm/29.5 lbf.ft (see Figure 11).



If the locking bolt does not hold the pins sufficiently, then grind a flat part to the assembling side of the pin.

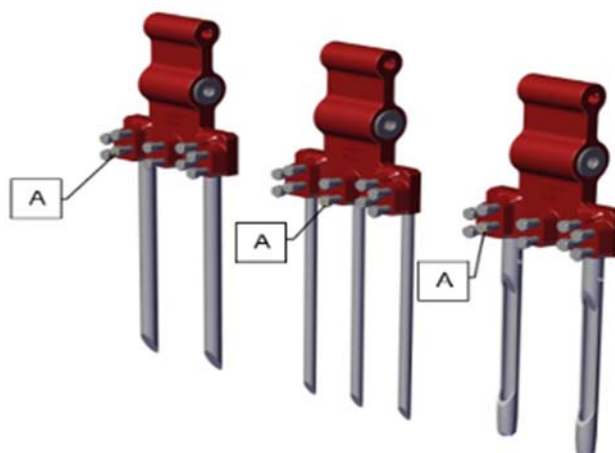

Figure 11

Solid pins

Solid pins break open the hard compressed soil. The pin angle adjustment determines the amount of heave movement in the ground. The heave movement becomes larger if the angle is adjusted from 90° to 70°. There is minimal heave movement in the ground if the setting is 90°.

If the pins are new, they can damage the lawn – certainly if the roots of the grass are weak. First, clean the pins manually *or* use the machine for 10 minutes on another rough underground. If the roots are weak, adjust the working depth in such a manner that the pricking depth is slightly deeper than the length of the roots. This way the roots have a chance to grow deeper. The next time prick deeper. Applying this method will prevent damage to the lawn and ensures a healthy set of roots.

We recommend using solid pins with the sharp point in the direction of the front roller (see Figure 12). You will then achieve the best possible heave movement in the ground.

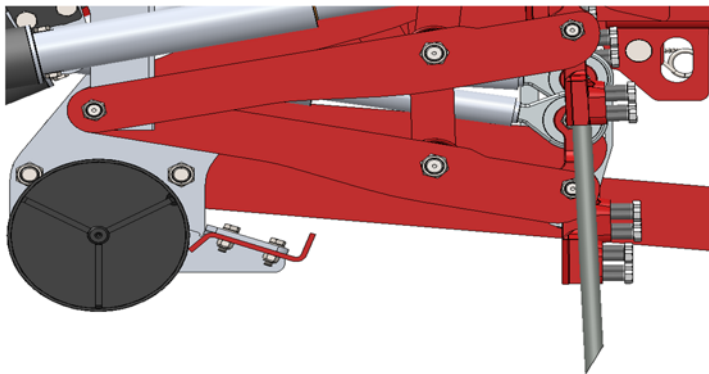

Figure 12

On the other hand, we recommend using pins with the sharp point in the direction of the rear of the machine in case of a lawn with weak roots (see Figure 13).

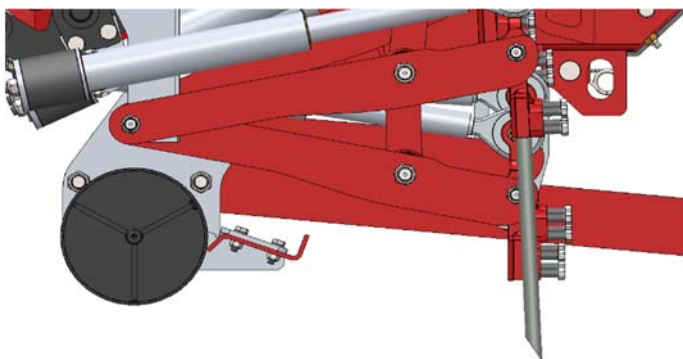

Figure 13

Always use pins of the same thickness and length. Replace a bent pin immediately. If you don't do this, the machine can become unstable. Do not use thicker and/or longer pins than the ones supplied for this machine (see Chapter 2).

Shorter (worn) pins can be used if superficial pricking is required. Be aware of the fact that the working depth indicated on the sticker will only be correct if the maximum length of the pin is used.

Oval holes are created if the top layer is weak and the substrate has a hard layer. Use thinner pins or wait until the wet top layer has become dry. Alternatively, use pins with a sharp point directed to the rear of the machine (see Figure 13).

If top dressing should be applied, apply this first *before* using the Verti-Drain® 2519.

If the soil is hard to aerate, sprinkle water on the soil. Afterwards, use thinner and shorter pins or adjust the working depth. If this is not done, the machine will ultimately suffer damage.

Hollow pins

The soil can be mingled with hollow pins. Various sizes are available (see the Parts page). The opening of the pin should be in the direction of the rear of the machine.

In case of using hollow pins, it is important that the pin angle is set to 90°. The heave movement of the pin in the soil is minimal and this way you make a nice 'clean' hole. The pin can ultimately break if the pin always moves in the soil under an angle smaller than 90°.

If a lot of dirt is created during pricking with hollow pins, reduce the revolutions or sprinkle water. Dirt can accelerate the wear & tear of the machine.

If the lawn becomes damaged, use solid pins first in order to create a set of healthy roots or adjust the working depth.

If the pins jam, then the soil is very compressed. First, you should use solid pins to break the soil open. Or sprinkle water or adjust the working depth.

12. MAINTENANCE

12.1 Maintenance schedule

Time schedule	Check point	Work activities
Before every use	Loose parts, bolts and nuts	Tighten loose bolts / nuts with the correct tightening moment (see Section 12.9).
	General check	Attach the machine to the tractor and operate the machine for 5 minutes. Listen and observe any strange movements / sounds.
	Check the oil level in the gearbox.	If necessary, use 80W90 GL5 – 1.2 litres (0.31 gallon)
	Safety stickers	Presence and readability of the safety stickers Replace these if not present or damaged.
	Loose hanging parts around the PTO	Tighten the parts so that they cannot reach the PTO.
After the first 20 working hours (new or repaired)	Lubricate the PTO and bearings.	Use 2 shots of EP2 grease. See Section 12.3 for the positioning of the grease points.
	Check for loose bolts / nuts.	Tighten loose bolts / nuts with the correct tightening moment (see Section 12.9).
	General check	Attach the machine to the tractor and operate the machine for 5 minutes. Listen and observe any strange movements / sounds.
	Check the oil level in the gearbox.	If necessary, use 80W90 GL5 – 1.2 litres (0.31 gallon)
	Loose hanging parts around the PTO	Tighten the parts so that they cannot reach the PTO.
After the first 50 working hours (new or repaired)	Change the oil in the gearbox.	If necessary, use 80W90 GL5 – 1.2 litres (0.31 gallon)
After every 50 working hours	Lubricate the PTO and bearings.	Use 2 shots of EP2 grease. See Section 12.3 for the positioning of the grease points.
	Check for loose bolts / nuts.	Tighten loose bolts / nuts with the correct tightening moment (see Section 12.9).
	Tension of the V-belt	If necessary, tension the V-belt (see Section 12.10).
	General check	Attach the machine to the tractor and operate the machine for 5 minutes. Listen and observe any strange movements / sounds.
	Check the gearbox for oil leaks.	Replace the seals.
After every 500 hours or after one (1) year	Change the oil in the gearbox.	If necessary, use 80W90 GL5 – 1.2 litres (0.31 gallon)

12.2 Cleaning

If a high-pressure cleaner is used to clean the machine, then observe the following rules:

- Do not use aggressive cleaning agents that can affect the machine.
- Maximum water pressure: 70 Bar (1015 PSI)
- Maximum water temperature: 50°C (122°F)
- Do not aim the jet of the high-pressure nozzle directly at the bearings, oil seals, lubrication points and stickers.
- Keep a minimum distance of 0.5 m (1.6 ft) between the head of the high-pressure cleaner and the surface you want to clean.



Grease the bearing points after cleaning the machine.

12.3 Lubrication points

To guarantee the proper functioning of the machine, all lubrication points at both sides of the machine must be greased periodically (see Figure 14). Grease these points according to the maintenance schedule (see **Section 12.1**).

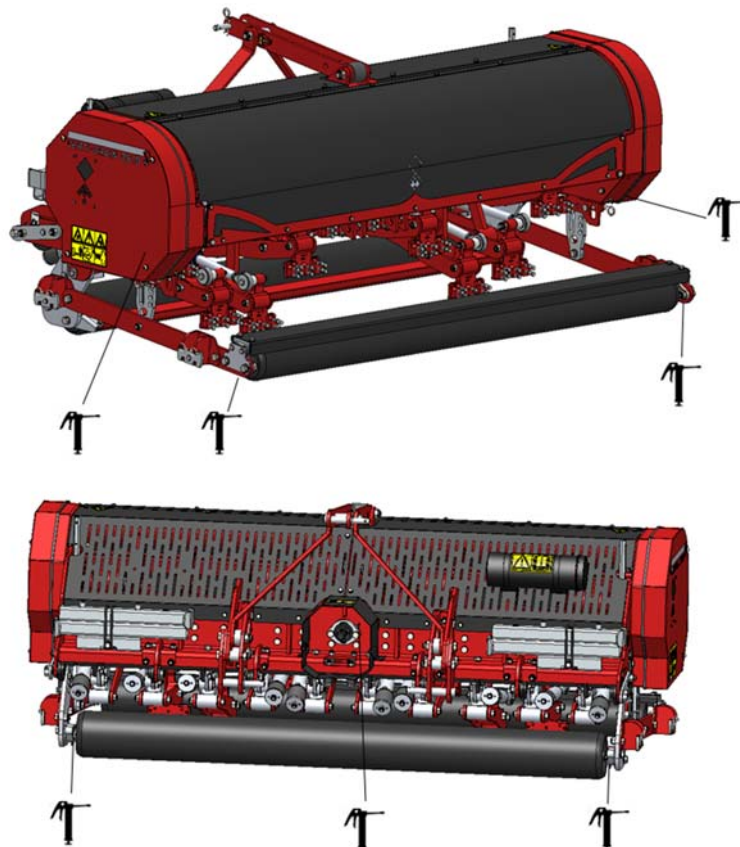

Figure 14

12.4 Adjusting the shock absorber

The length of the shock absorber is very important for the proper operation of the machine. This length must be minimum 476 mm (18.74"). If the length is larger, the machine could get damaged.

Calibrate the shock absorber as follows (see Figure 15):

1. Unscrew the nut **(2)**.
2. Rotate the large ring **(1)** until the required length is achieved.
3. Tighten the nut **(2)** again.



If the required length cannot be achieved, then most likely the rubber buffer **(3) has worn out and should be replaced.**

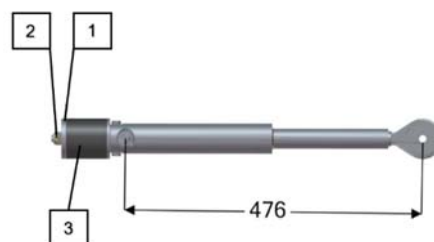

Figure 15

12.5 Checking the oil level in the gearbox

The machine has a gearbox centrally located at the rear side of the machine. Do the following for checking the oil level in the gearbox (see Figure 16):

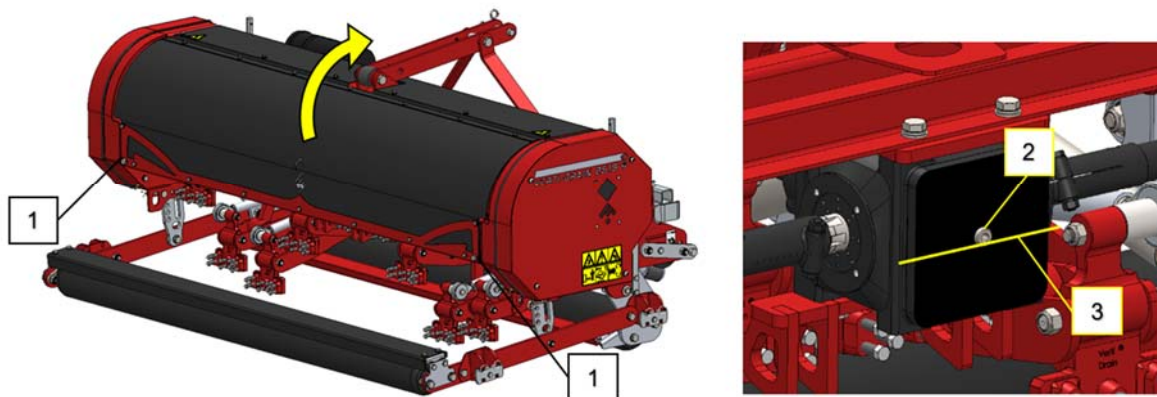

Figure 16

1. Make sure that the machine is horizontal.
2. Unscrew the bolts **(1)** and open the rear cover.
3. Check the oil level by removing the screw **(2)**.
4. The gearbox should be filled up to the bottom of the screw hole, the level line **(3)**.
5. If necessary, top up the oil in the gearbox up to the level line **(3)** using 80W90 GL5 oil.
6. Mount the screw **(2)** and tighten it.
7. Close the rear cover and screw the bolts **(1)** tightly.

12.6 Crankshaft

Figure 17 illustrates the composition of the crankshaft. Also look at the Parts page for a more detailed drawing.

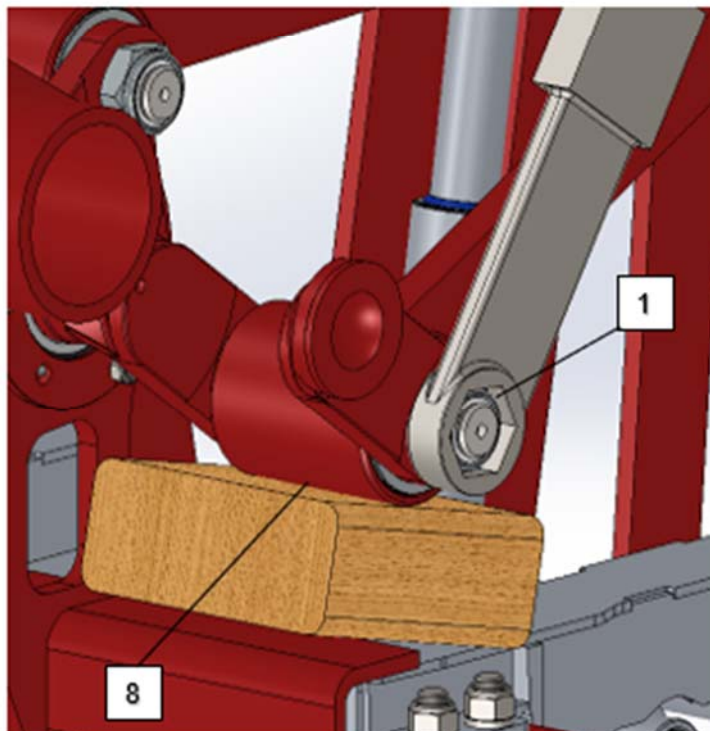
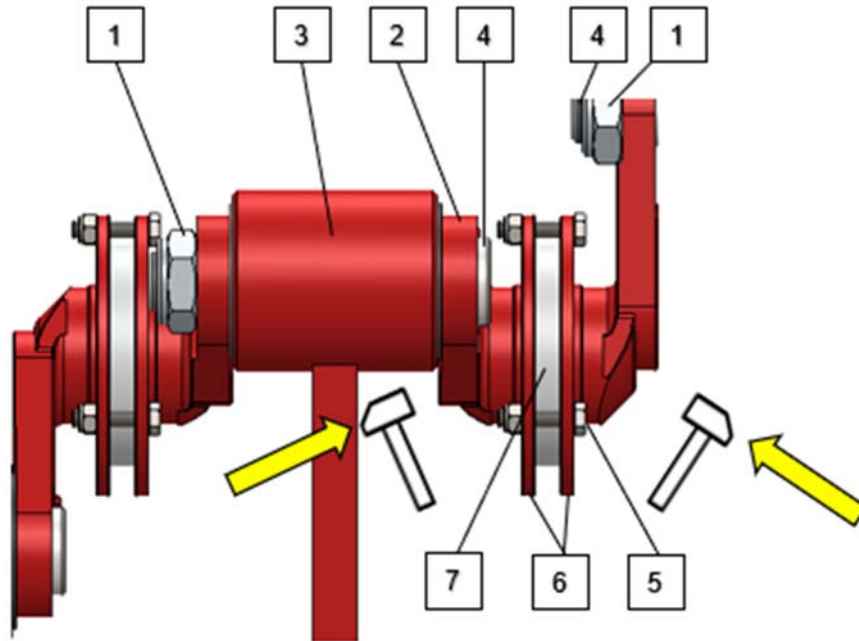

Figure 17

12.7 Replacing a crank / Crank bearing

Replacing a crank is necessary if the crank is cracked or if the nuts **(1)** of the drive rod come undone regularly. Then the crank bearings, the crank bearing holes or the big-end pinholes in the crank are damaged. To prevent further damage to other parts, as soon as possible replace the crank / bearing as follows (see Figure 17):

1. Remove the big-end nut **(1)** and the big-end pin **(4)**.
2. Remove the drive rod **(3)**.
3. Remove the bolts and nuts **(5)** and the closing plates **(6)**.
4. Remove the crank **(2)**.
5. Check the bearing and if necessary, remove the bearing **(7)**.
6. Replace the faulty parts and assemble in the reverse order.



Use Loctite 270 for nuts 1.



For tightening moments, see Section 12.9.



For the correct assembly, support the middle of the drive rod **(8) using a wooden block when tightening the big-end nut **(1)** (see Figure 17).**

12.8 Eliminating crankshaft tensions

If parts in the crankshaft are replaced, the crankshaft can run heavier. Pre-tension can be the cause. It is necessary to eliminate these tensions as follows:

1. Check which crank **(2)** runs heavier and causes tension.
2. Using a hammer, beat on the specific cranks besides the big-end nut that causes the tension in order to eliminate this tension (see Figure 17).
3. Check each crank **(2)** for tension until the tension is eliminated in all elements.



To prevent damaging the crankshaft, do NOT start working with the machine before all pre-tension is removed from the crankshaft.



After repairing the crankshaft, you must regularly check whether nuts come undone.



Assemble the cranks in the correct manner. See the Parts page for the correct order and part numbers.

12.9 Timing and tightening moments

Figure 18 shows the tightening moments of the most important bolts and nuts. Make sure that the tightening moments of bolts and nuts for which the settings are not listed are the same as the tightening moments of comparable bolts and nuts. If bolts and nuts come undone, Loctite may be used to tighten them.

Because the timing of the machine is symmetrical, only two different cranks are used. The crank in the middle divides the machine in two in which each of the two halves has its own type of crank element. At the end, the crankshaft has the same end-crank. Consult the Parts manual to mount the crankshaft correctly. This way, the timing of the crankshaft will always be correct.

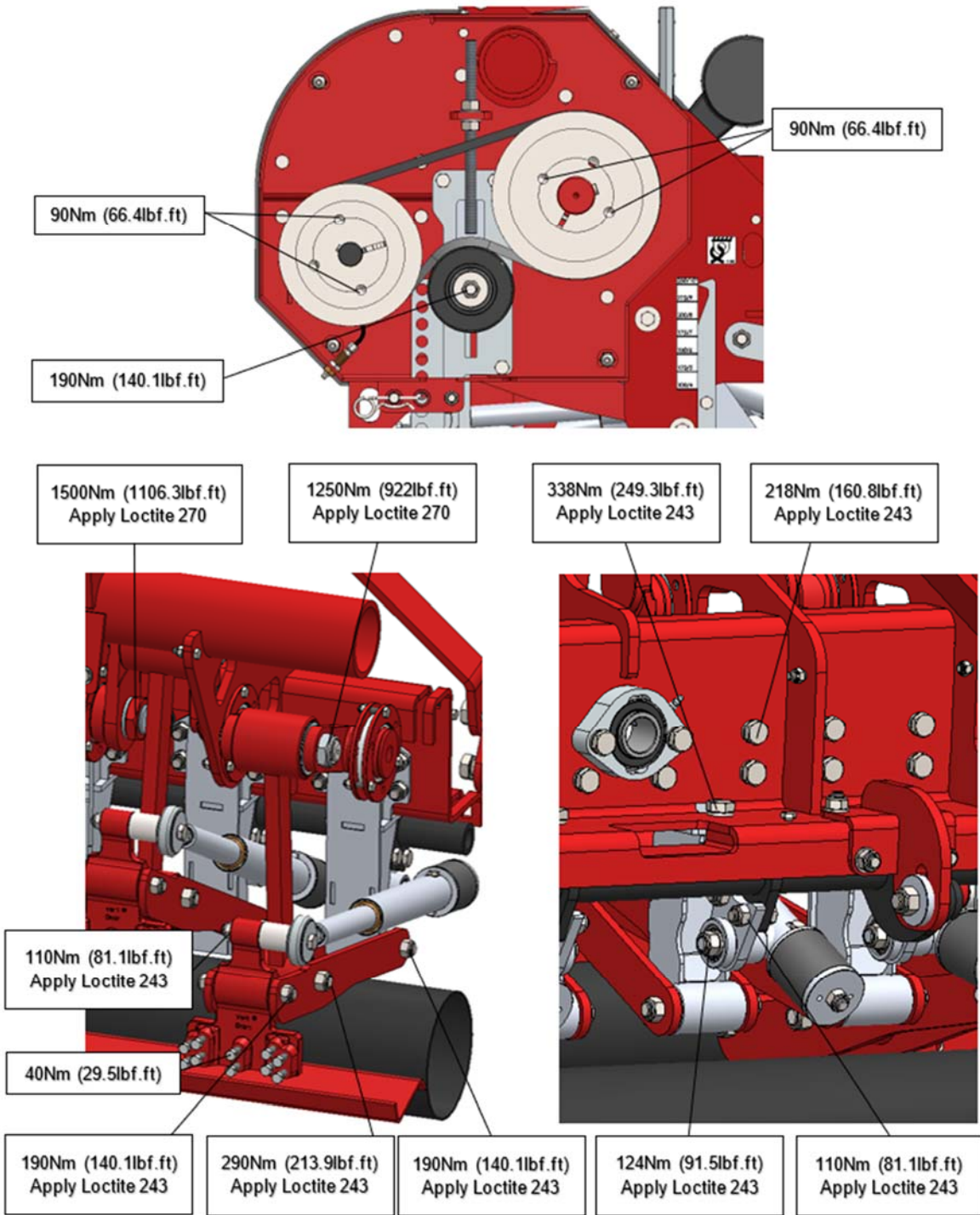

Figure 18

12.10 Mounting and dismounting the taper-lock clamping bush

Carry out the following instructions for the correct mounting and dismounting of the taper-lock clamping bush (see Figure 19)

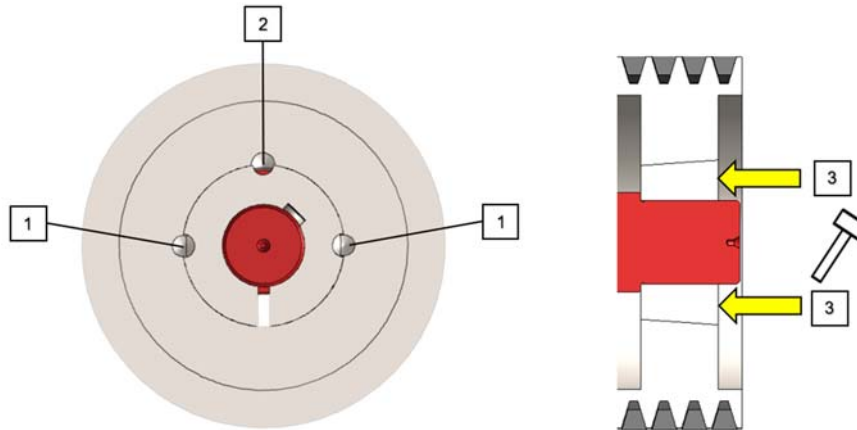

Figure 19

Mounting:

1. Thoroughly clean the clamping bush / pulley and axle, so that grease and other dirt are removed from them.
2. Place the clamping bush in the pulley in the correct position. The three holes (1 + 2) of the clamping bush must be aligned with the holes of the pulley.
3. Apply oil to the socket-screws, insert them into the holes (1) and screw them hand-tight.
4. Place the pulley including the clamping bush over the axle and position in the required position.
5. Tighten both socket-screws evenly until the corresponding tightening moment is achieved.
6. Using a hammer and a wooden chock or adaptor ring, beat the outermost ring surface (3) of the clamping bush to settle the ring.
Tighten the socket-screws again, until the corresponding tightening moment is achieved. Repeat this once or twice.
7. Let the machine run for approx. one (1) hour and check whether the moment of the socket-screws has not deviated. If this is the case, tighten the socket-screw(s) until the corresponding tightening moment is achieved and repeat the procedure.

Clamping bush	Tightening moment
1008/ 1108	6 Nm (4.4lbf.ft)
1210/ 1215/ 1310/ 1315/ 1610/ 1615	20 Nm (14.8 lbf.ft)
2012	30 Nm (22.1 lbf.ft)
2517	50 Nm (36.9 lbf.ft)
3020/ 3030	90 Nm (66.4 lbf.ft)
3535	115 Nm (84.8 lbf.ft)

Dismounting:

1. Remove the socket-screws from position 1.
2. Apply oil to one socket-screw and place it in position 2.
3. Tighten the socket-screw up to the point that the clamping bush comes loose from the pulley. Remove both parts from the axle.

12.11 Adjusting the tension of the v-belts

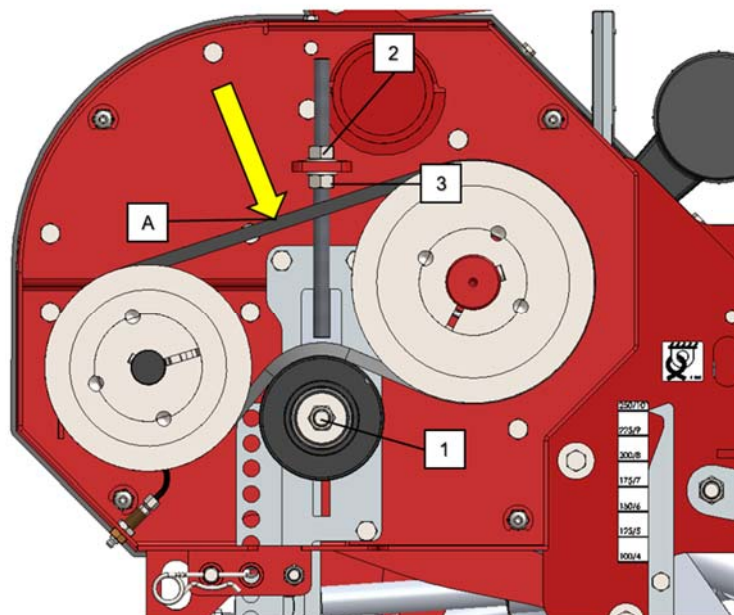

Figure 20

The Verti-Drain® 2519 is equipped with adjustable tension pulley that keeps the V-belts taut. Depending on the intensity of using the machine, the driveline could be affected by wear and tear. This can result in slipping of the V-belts; they should then be retightened.

Retightening is carried out as follows (see Figure 20):

- ⚠ Make sure that the Verti-Drain® 2519 is blocked well and cannot move on its own accord.**
 - ⚠ Make sure that the PTO is detached from the Verti-Drain® 2519!**
1. Remove the safety guards.
 2. Check the tension of the V-belt by depressing the centre of the V-belt in point A using a tension of 7.5 kg (16.5 lbs). Per belt, the depression should be 9 mm (0.35"). Go to point 7 if the tension is correct and go to point 3 if the tension should be adjusted.
 3. Loosen bolt (1) a single turn so that the tension arrangement can slide.
 4. Adjust the nuts (2 & 3) and this way, adjust the tension of the V-belts.
- ⚠ Important: Make sure that all V-belts have the correct tension, so that the load is equally divided over the V-belts at the left-hand and right-hand sides of the machine.**
5. Tighten the nut (1).
 6. Contra-tighten the nuts (2 & 3) against each other.
 7. Place the safety guards.
- ⚠ The V-belt tension is important and should be checked regularly.**

13. TROUBLE SHOOTING (PROBLEM ANALYSIS)

Problem	Possible cause	Solution
Machine vibrates.	Crankshaft turns irregularly.	<ul style="list-style-type: none"> - Machine is not horizontal. - Angles of the PTO's turning points are different.
	Difficult conditions	<ul style="list-style-type: none"> - PTO's turning points are not aligned. - Adjust the working depth. - Use shorter / thinner pins. - In case of drought, first sprinkle water.
Solid / hollow pins break and/or bend.		<ul style="list-style-type: none"> - Change the pin; use shorter ones. - Use solid pins in front of the hollow pins to break the soil open.
	Difficult conditions	<ul style="list-style-type: none"> - Adjust the working depth. - Use shorter / thinner pins. - In case of drought, first sprinkle water.
	Rapid wear & tear	<ul style="list-style-type: none"> - First use solid pins to break up the soil. - Adjust the pin angle.
Front roller does not stand stable on the ground.	Wrong pins; too much resistance	<ul style="list-style-type: none"> - Adjust the working depth. - Use different pins.
	Difficult conditions	<ul style="list-style-type: none"> - Adjust the working depth. - First sprinkle water.
PTO breaks.	Shafts crack.	<ul style="list-style-type: none"> - PTO angles are too large. - Angles of the PTO's turning points are different.
Damage to the absorbers	Bending / breaking	<ul style="list-style-type: none"> - Machine is not horizontal. - Angle adjustment of the central bar is bent. - Bearing bushes are worn out. - Pins touch the ground when reversing the machine.
Damage to the lawn	Oval holes	<ul style="list-style-type: none"> - Soil is too wet. - Change the pin angle setting. - Reduce the forward driving speed. - Adjust the working depth. - Use thinner pins. - Turn the pins so that the points are directed toward the rear side of the machine.
Pin comes loose from the pin holder.	Difficult conditions	<ul style="list-style-type: none"> - Use different pins. - Grind a flat part to the pins. - Adjust the pin angle.
Crankshaft problems	Big-end nuts come undone.	<ul style="list-style-type: none"> - Determine the place of the vibration in the machine and rectify this. - Crankshaft bearing is worn. - Incorrect assembly after repair
Distance between the holes is irregular.	V-belts are slipping.	<ul style="list-style-type: none"> - Tension the V-belts.