

# User manual and parts book Vibra-Sandmaster

Redexim 

**Model: 1600**

Kwekerijweg 8  
3709JA Zeist  
The Netherlands  
T: (31)306933227  
F: (31)306933228  
E: [verti-drain@redexim.com](mailto:verti-drain@redexim.com)  
[www.redexim.com](http://www.redexim.com)

**Serial number:**

Translation of the original user manual

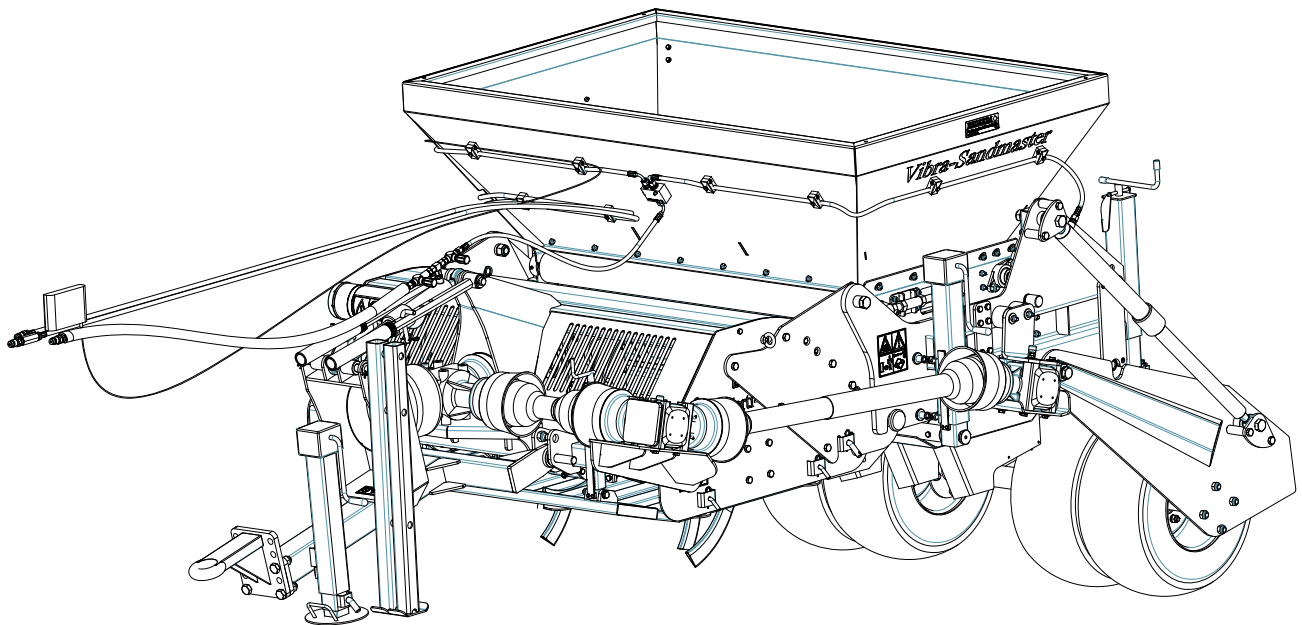

115PR003-MN01-1

**NOTE:**

IN THE INTERESTS OF SAFETY AND ACHIEVING THE BEST RESULT, IT IS VERY IMPORTANT THAT THIS MANUAL IS READ CAREFULLY BEFORE USING THE VIBRA-SANDMASTER.



## FOREWORD

Congratulations with the purchase of your Vibra-Sandmaster. This manual must be read carefully in order to ensure safe and long-term operation of this Vibra-Sandmaster. Safe operation of this machine is not possible if the user is not fully familiar with the contents of this manual.

The Vibra-Sandmaster is not a stand-alone machine. It is the responsibility of the user to use the correct tractor. The user also has to perform safety-related checks on the tractor / Vibra-Sandmaster combination including sound level, user instructions and risk analysis.

The Vibra-Sandmaster is solely intended for use on fields or other areas where grass can grow.

The general safety instructions will be covered on the next page. All users must be familiar with and apply these instructions. There is a registration card below, which must be sent back in order to process any future claims.

This user manual contains numerous instructions, which are numbered in sequence. This working sequence must be adhered to. The  pictogram indicates safety instructions. The  pictogram indicates a tip and/or note.

All information and technical specifications used are the most recent at the time of publication. Design specifications are subject to change without notice.

This document is a translation of the original user manual.  
The original user manual (Dutch language) is available on request.

## WARRANTY CONDITIONS

THIS VIBRA-SANDMASTER IS SUPPLIED WITH A WARRANTY FOR DEFECTS IN MATERIALS. THIS WARRANTY IS VALID FOR A PERIOD OF 12 MONTHS FROM THE DATE OF PURCHASE. VIBRA-SANDMASTER WARRANTIES ARE SUBJECT TO THE "GENERAL CONDITIONS FOR SUPPLY OF PLANT AND MACHINERY FOR EXPORT, NUMBER 188", WHICH WERE PUBLISHED UNDER THE AUSPICES OF THE UNITED NATIONS ECONOMIC COMMISSION FOR EUROPE.

## REGISTRATION CARD

Complete the table below for your own records:

Machine serial number	
Dealer name	
Purchase date	
Comments	

# ! SAFETY INSTRUCTIONS !

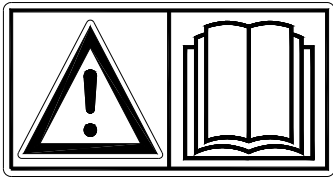

Fig. 1

The Vibra-Sandmaster is designed for safe use. This is only possible if the safety instructions defined in this manual are observed in full.

**Read and understand** (Fig. 1) the manual before proceeding to use the Vibra-Sandmaster. Failure to use the machine as described in the manual can result in injury and/or damage to the Vibra-Sandmaster.

- (1) The Vibra-Sandmaster is solely intended for use on fields or other areas where grass can grow.

The manufacturer accepts no liability whatsoever for incompetent use and any damage arising from this; the user bears full responsibility for all risks arising from this.

The prompt and correct execution of the user, maintenance and repair instructions prescribed by the manufacturer also constitutes competent use.

Inspect the area for treatment prior to using the Vibra-Sandmaster.

Remove any free-standing obstacles and avoid irregularities.

- (2) The Vibra-Sandmaster has been manufactured in accordance with the latest technological knowledge and is safe for use.

There is a risk of injury for the user and third parties if the machine is operated, maintained or repaired by improper persons. **This must be avoided!**

**Always use the Vibra-Sandmaster in combination with the correct tractor, as defined in the technical data.**

- (3) All persons appointed by the owner as authorised to operate, perform maintenance on or repair the Vibra-Sandmaster must have read and fully understood the content of the operation manual and the **Safety guidelines** section in particular.

The user is responsible for a **safe Tractor / Vibra-Sandmaster combination. The system as a whole must be tested** for sound, safety, risk and ease of use. User instructions must also be drawn up.

- (4) The user has an **obligation** to check the Vibra-Sandmaster for **visible damage and defects before use**.

Changes to the Vibra-Sandmaster (including the operation) that are detrimental to safety must be rectified immediately.

For safety-based reasons, adapting or adding to the Vibra-Sandmaster (with the exception of factory approved changes) is not permitted as a rule.

**Modifications** to the Vibra-Sandmaster will render the current CE marking ineffective and the **person who performed** the modifications is responsible for arranging new **CE marking**.

Check the Vibra-Sandmaster for loose bolts / nuts / parts prior to each use.

Regularly check any hydraulic hoses and replace these if damaged or show signs of ageing. The replacement hoses must meet the manufacturer's technical requirements.

If present, the hydraulic system must be depressurised **at all times** before performing any activities on it.

The Vibra-Sandmaster may **NEVER** be used if the safety guards and safety stickers are not present.

**NEVER** crawl underneath the Vibra-Sandmaster.  
Tilt Vibra-Sandmaster if required.

**NEVER** get off the tractor while the engine is still running.

The Vibra-Sandmaster must be blocked to prevent it from lowering / driving off / sliding away when performing maintenance, adjustment and repair activities.

**Always switch off the tractor engine, remove the tractor ignition key and disconnect PTO** when performing maintenance, adjustment and repair activities (Fig. 2).

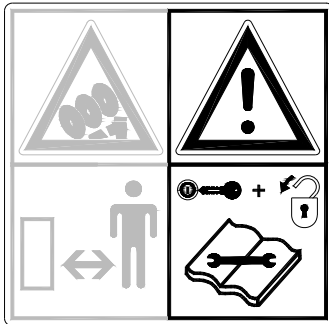

Fig. 2

Only use original Vibra-Sandmaster parts for maintenance or repair activities in order to guarantee the safety of the machine and user.

Adjustments and repairs to the Vibra-Sandmaster must be performed by authorised, technical staff only.

**Maintain a repairs record.**

- (5) In addition to the instructions in this user manual, the prevailing safety standards and Occupational Health and Safety regulations must be observed.

The governing procedures of the traffic regulations apply to use on public highways.

**Transport of persons is not permitted!**

Do not use the Vibra-Sandmaster during hours of darkness, heavy rain/storm or on slopes with a gradient greater than 20 degrees.

All persons using the Vibra-Sandmaster must be familiar with all functions and operational elements of the machine prior to commencing the activities.

Connect the Vibra-Sandmaster to the pulling vehicle as stated in the instructions.

**(Injury hazard!)**

Ensure that you have a clear long distance view and clear sight of the immediate vicinity.

There are safety stickers (Fig.5) on both sides of the Vibra-Sandmaster, one on the side panel (Fig. with an identical meaning. These safety stickers must be clearly visible and legible at all times and replaced when damaged.

Persons must **STAY out of the hazard zone** of the Vibra-Sandmaster when operational, as there is a physical injury hazard due to rotating parts. (Fig. 3)

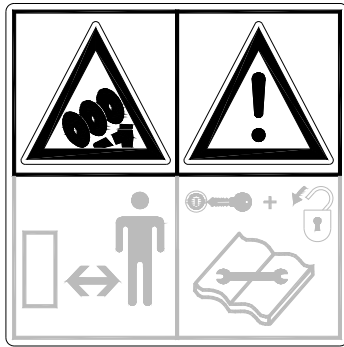

Fig. 3

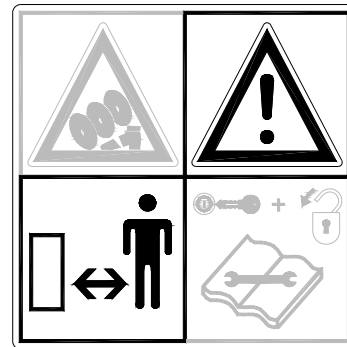

Fig. 4

**Maintain a safe distance of at least 4 metres!** (Fig. 4)

Observe the permitted lifting capacity of the pulling vehicle.

Wear appropriate clothing. Wear steel toecap safety shoes, long trousers, secure long hair and do not wear loose clothing.

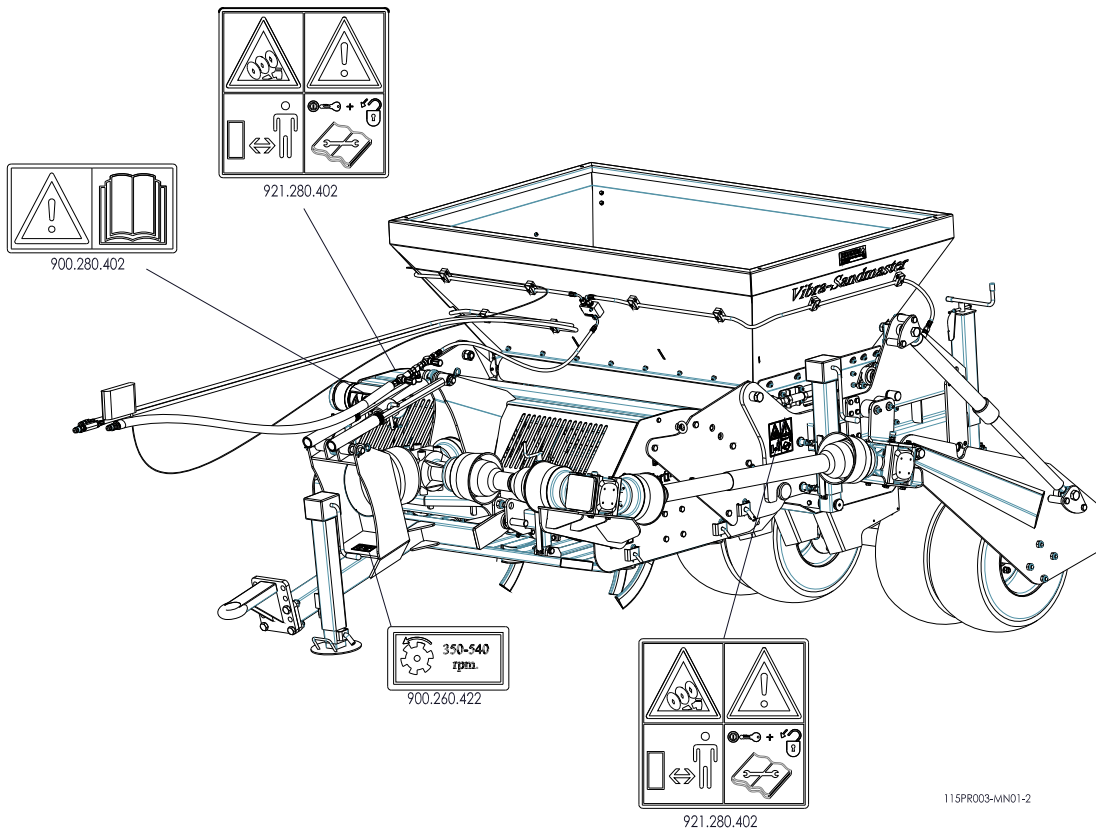

Fig. 5

(7) Locations of safety stickers. (Fig 5.).

***Used oil / grease constitutes an environmental hazard and must be disposed in accordance with current regulations.***



## EU DECLARATION

We,

**Redexim BV  
Utrechtseweg 127  
3702 AC Zeist, the Netherlands**

declare entirely under our own responsibility that the product:

**VIBRA-SANDMASTER WITH MACHINE NUMBER AS STATED ON THE MACHINE AND IN THIS MANUAL.**

to which this declaration refers, complies with stipulation of the 2006/42/EC machine directive and is in conformity with the following standards: NEN-EN-ISO 12100 : 2010 NEN-EN-ISO 13857 : 2008

Zeist, 12-2-2013

A handwritten signature in blue ink, appearing to be 'A.C. Bos', written over a horizontal line.

**A.C. Bos  
Manager Operations & Logistics  
Redexim Holland**

## TABLE OF CONTENTS

FOREWORD .....	2
WARRANTY CONDITIONS.....	2
REGISTRATION CARD.....	2
! SAFETY INSTRUCTIONS !.....	3
EU DECLARATION .....	6
1.0 TECHNICAL DATA.....	8
2.0 GENERAL DESCRIPTION.....	8
3.0 FIRST INSTALLATION, UNLOADING THE MACHINE FROM THE PALLET.....	9
4.0 LINKING UP THE VIBRA-MASTER WITH THE VERTI-QUAKE .....	11
5.0 THE PTO .....	12
5.1 LENGTH OF THE PTO .....	12
5.2 USING THE PTO.....	13
5.3 PTO INFORMATION AND MAINTENANCE .....	13
5.4 ABRIDGED MAINTENANCE SCHEDULE PTO.....	14
6.0 CONNECTING TO THE TRACTOR.....	15
7.0 WORKING DEPTH ADJUSTMENT.....	16
7.1 SETTING LIFTING / LOWERING ORDER.....	17
7.2 SETTING MATERIAL SUPPLY .....	18
8.0 USING THE VIBRA-SANDMASTER .....	19
9.0 OPERATING SPEED .....	19
10.0 TRANSPORTING THE VIBRA-SANDMASTER.....	19
11.0 START / STOP PROCEDURE .....	20
12.0 DISCONNECTING THE VIBRA-SANDMASTER .....	21
13.0 TROUBLESHOOTING.....	22
14.0 LUBRICATING POINTS .....	23
14.1 MAINTENANCE .....	24
14.2 REPLACING THE FILLING COULTERS.....	25
14.3 RETENSIONING THE CONVEYOR.....	26

## 1.0 TECHNICAL DATA

<u>Model</u>	<u>Vibra-Sandmaster 1600</u>
Operating width	1.56 m (61.4")
Operating depth	125-200 mm (4.9"-7.9")
Tractor speed measured at 540 rpm at PTO.	0.5 - 1.5 Km/h 0.3 - 0.9 mph
PTO rpm: (max.)	540
Weight	2035 Kg / 4486.4 lbs (without Verti-Quake 2516) 2650 Kg / 5842 lbs (with Verti-Quake 2516)
Number of Filling coulters	6
Distance between the Filling coulters	260 mm (10.2")
Thickness of the Filling coulters	25 mm (0.98")
Recommended tractor	Min. 65-90 hp with four-wheel drive
Maximum operating capacity	2400 m <sup>2</sup> /h 25833 ft <sup>2</sup> /h
Dimensions (with Verti-Quake 2516)	4,26x2,26x2,10mtr 167.7"x89"x82.7"
Hopper loading height	2.1m (82.7") (Elevated machine) 1,5m (59") (Deepest operating position)
Hopper capacity	1.5m <sup>3</sup>
Hydraulic connection value	1 single operating valve (Elevating the machine) 2 double operating valves (Conveyor drive)
	Flow min. 15 l/min (4 Gallon/min) Pressure min.180 bar (2610 PSI)
Tyre pressure	0.8-1.8 bar (11.6-26 PSI)
Gearbox oil	(See parts manual for specifications).
Lubricating grease	EP2 + High Grade Grease HT Q9 (drive line)

## 2.0 GENERAL DESCRIPTION

The Vibra-Sandmaster is a machine that operates linked up in combination with another machine, the Verti-Quake.

The combination makes grooves in the subsoil and fills the grooves with a material such as sand or soil conditioner, up to a depth of 200mm.



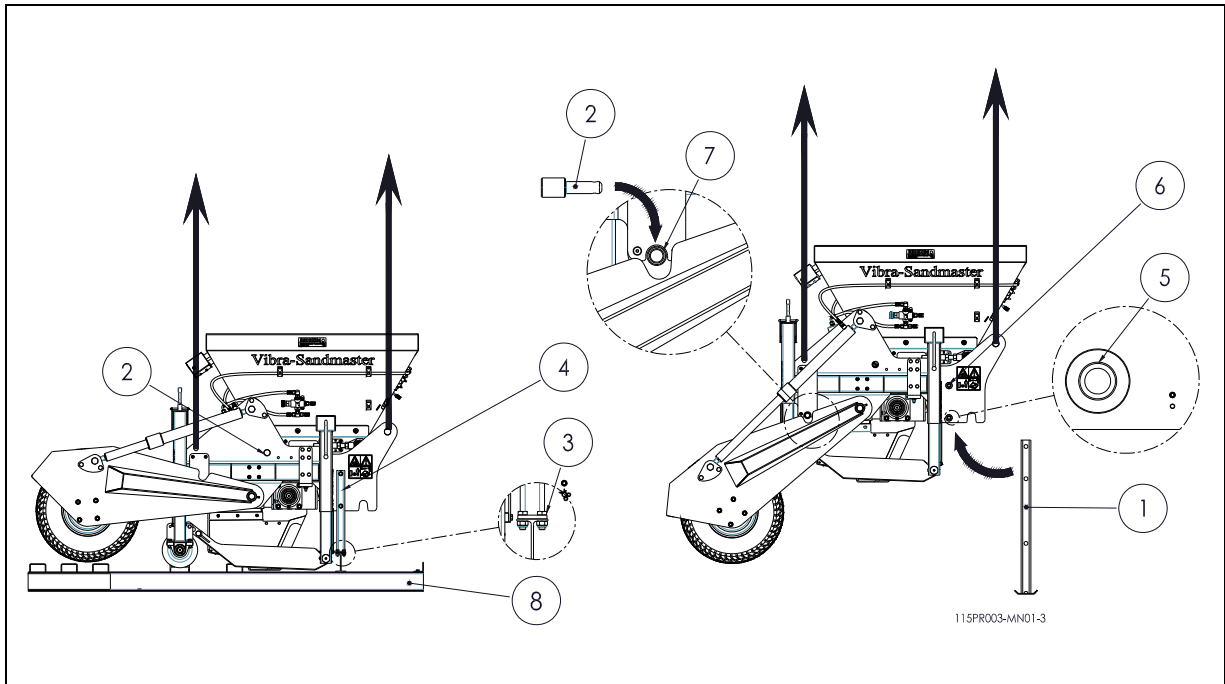

Fig. 6

### 3.0 FIRST INSTALLATION, UNLOADING THE MACHINE FROM THE PALLET

To remove the pallet and place the machine on the floor horizontally, follow the instructions below: (fig. 6)

**⚠ !! NEVER CRAWL UNDERNEATH THE MACHINE !!**

1. Take all unattached parts from the pallet and machine.
2. Remove the supports 1 out of the hopper.
3. Secure a hoisting cable to the lifting points.

**⚠ Ensure that the cable / crane / lift can lift at least twice the weight of the machine (see section 1.0 technical data, to obtain information about weight).**

4. Slightly lift the machine to take the load off the pallet so that the bolts 3 can be unscrewed.
5. Remove the pallet supports 4.
6. Move the lowest pins 5 into the most forward position.
7. Lift the machine further so that the supports 1 can be mounted to the pins 5&6 and secure with the corresponding clips (both sides of the machine).
8. Lift the machine further so that the rear wheels have lowered sufficiently to enable mounting the locking pins 2 in hole 7. Secure with the corresponding clips (both sides of the machine).

**⚠ !! WARNING! MAINTAIN A SAFE DISTANCE AS THE MACHINE MAY START TO SLIDE !!**

9. Remove the pallet 8 from underneath the machine.
10. Carefully and slowly lower the machine until its full weight is on the floor.
11. Remove the hoisting cables.

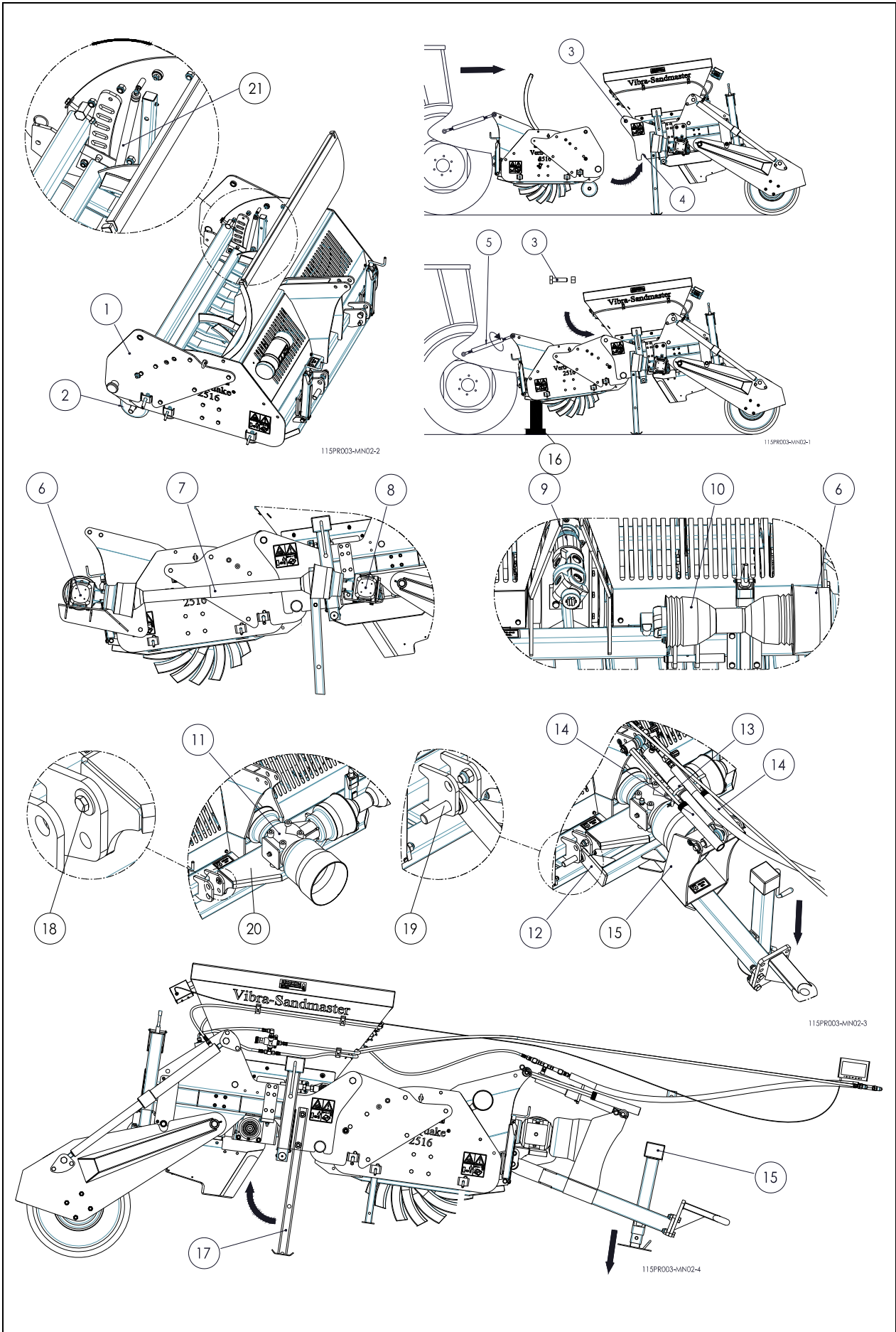

Fig. 7

## 4.0 LINKING UP THE VIBRA-MASTER WITH THE VERTI-QUAKE

(See Fig.7)



**For a more extensive description of the position and specification of the parts, see the parts manual.**



**For the pre-installation of the Verti-Quake please refer to the Verti-Quake manual.**

1. Fit the side plates 1 to the Verti-Quake.
2. Remove rear roller 2 of the Verti-Quake.
3. Remove one of the gas struts 21 which hold the skids. (too heavy to push it down now)
4. Connect the Verti-Quake to the tractor by means of the 3-point connection (see the Verti-Quake manual for the procedure).
5. Remove the bolts 3 from the Vibra-Sandmaster.
6. Lift the Verti-Quake and carefully ride it between the coupling plates of the Vibra-Sandmaster and lift it in the grooves 4.
7. Rotate the top rod of the tractor so that the bolts 3 can be fitted and secure them with the corresponding nuts.



**Ensure that the locking pins are properly fitted and secured with the clips.**

8. Support the Verti-Quake at the front 16.



**Ensure that the Verti-Quake is properly supported, that the support can carry the load of the machine and that the unit as a whole is stable before continuing to the next step.**

9. Disconnect the Verti-Quake from the tractor (see the Verti-Quake manual for the procedure).
10. Mount gearbox 6 and connect it to the enclosed PTO axle 7 (unsecured) between gearboxes 6 and 8.
11. Fit the short PTO with cam coupling 9, with the coupling side to the Verti-Quake side.
12. Fit the short PTO 10 to gearbox 6.
13. Connect the PTO axles to gearbox 11 and connect plate 20 to the filler bush, bolt and nut 18 at the top holes of the lowest three-point suspension of the Verti-Quake.
14. Fit towing hook 12 to the lowest holes of the lowest three-point suspension of the Verti-Quake by means of the enclosed three-point pins 19 and secure them with the corresponding clips.
15. Rotate the supports 15 of towing hook 12 downwards.
16. Fit the hydraulic top rod 13 with blocking system 14 and secure the pins with the corresponding clips (see the parts manual for the order of the rings and pins).
17. Rotate support 15 downwards so that supports 17 can be removed and fit them to the side of the hopper.

## 5.0 THE PTO

The PTO is a very important part. It provides the drive from the tractor and ensures, if correctly maintained and installed, safe use of the machine. The PTO has dedicated CE certification.

 **Read the PTO manual, which can be found on the actual PTO.**

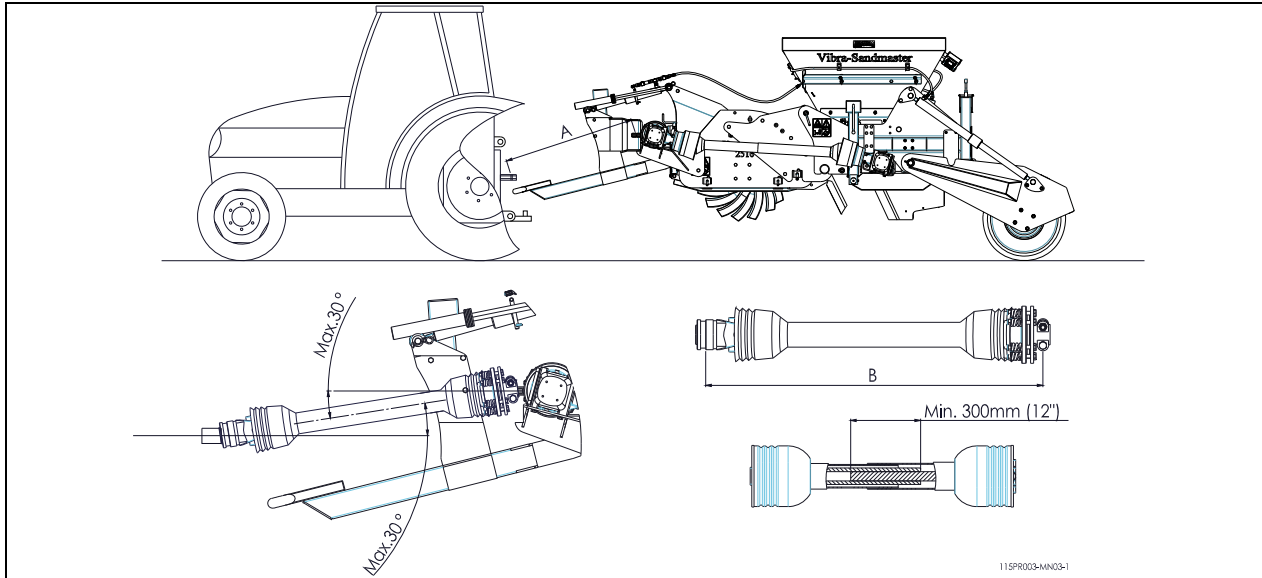

Fig. 8

## 5.1 LENGTH OF THE PTO

The length of the PTO is very important. The drive on the tractor and/or Vibra-Sandmaster may get damaged if this is too long.

The PTO may get damaged if the length of the tube overlap drops below 300 mm (12") at any given time.

 **!! The length changes when the machine is lifted or if another tractor is used !!**

The procedure for correctly adjusting the length of the PTO if newly purchased or if another tractor is used is as follows (See fig.8):

1. Connect the Vibra-Sandmaster to the tractor as described in section 6.
2.  **!! Switch the tractor off and ensure that the tractor is properly blocked and cannot move position independently !!**
3. Lower the Vibra-Sandmaster to the floor until the blades nearly touch the surface and the slider feet are parallel to the surface.
4. Measure the distance A between the PTO connection on the tractor and the Vibra-Sandmaster connection, from groove to groove.
5. Measure the length B of the PTO when in the shortest position from locking pin to locking bolt.
6. Split the PTO into two parts and remove the safety guards from both ends.
7. Both the ends of the tubes and the safety guards must be shortened.  $(B-A) + 150 \text{ mm}$  (6").
8. Burr all parts, use a little grease and reassemble all parts.
9. Fit the PTO with the safety device to the Vibra-Sandmaster side.
10. Secure the other end of the PTO to the tractor.
11. Check the tube overlap.

 **!! Never use the machine if the PTO safety guard is damaged: Replace this first !!**

## 5.2 USING THE PTO

Correct use of the PTO requires checks of the following items:

1. When operational, the angle of the centres of rotation may never exceed 30 degrees.
2. The centres of rotation must always be aligned.
3. The minimum tube overlap is 300mm (12").
4. Never use the machine if the PTO safety guard is damaged.

## 5.3 PTO INFORMATION AND MAINTENANCE

The compiled Vibra-Sandmaster machine benefits from double protection against overloading.

The first safety device concerns a slip coupling fitted on the PTO of the tractor to the 1<sup>st</sup> gearbox to protect the Vibra-Sandmaster.

Provided the system is used and maintained correctly, the slip coupling will protect the machine against damage.

The following items are important:

1. By default, the length of the spring is set at 33 mm (1.3")
2. If the slip coupling slips, the bolts / nuts may be tightened a quarter turn per occurrence, until the minimum length of 31.5mm (1.25") of the spring has been reached. Further compression will overload the machine.



**If the bolts / nuts are tightened too much, the machine may ultimately get damaged or create unsafe situations.**

The second safety device concerns a cam coupling in the PTO between the 1<sup>st</sup> gearbox and the Verti-Quake to protect the Verti-Quake.



**!! If the cam coupling is activated, the PTO must be switched off, the machine lifted from the ground and the start procedure must be repeated !!**

## 5.4 ABRIDGED MAINTENANCE SCHEDULE PTO

Periodic maintenance:

- Grease the lubricating points every 80 operational hours or after a long period of inactivity.
- Check the PTO for any damage to the safety guards and replace these if they are no longer sound.
- Check that the safety stickers are in place on the PTO and are not damaged.

Annual maintenance:

- Remove the PTO from the machine.
- Inspect the PTO parts.
- Arrange all parts and carefully inspect them.  
Replace any damaged or worn parts.
- Clean all grip connections between parts.
- Reassemble all parts.
- Grease both tubes and reassemble both PTO parts.
- Reassemble the PTO and fit it to the machine.

**See the manual supplied with the PTO for additional information about maintenance and dismantling the PTO.**



**The gearbox may be exposed to a higher load if the PTO has been shortened incorrectly or another tractor is used. This can cause damage.**

## 6.0 CONNECTING TO THE TRACTOR

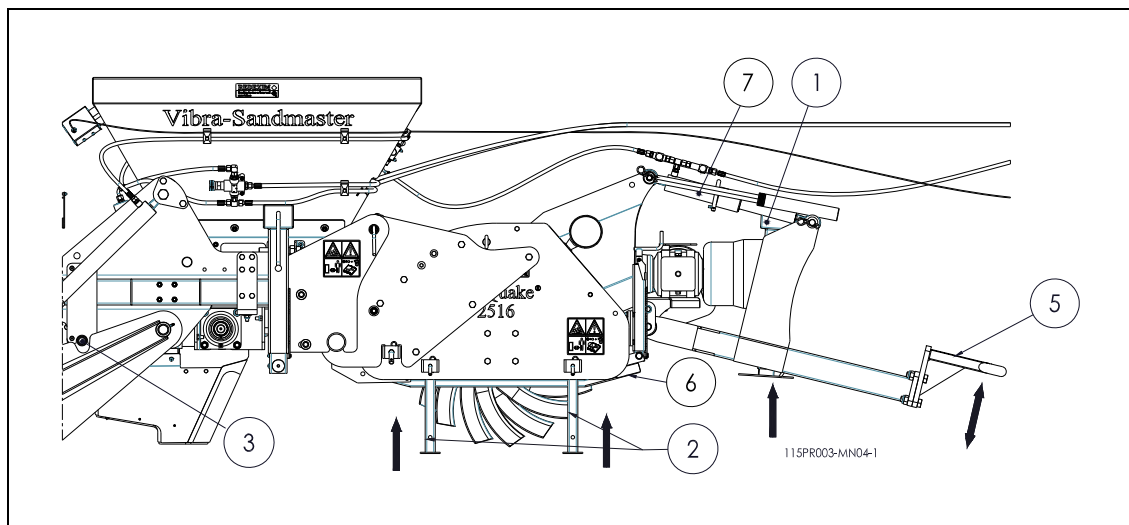

Fig. 9

Check procedure before proceeding to connect the Vibra-Sandmaster.

- Check the Vibra-Sandmaster for visual damage and repair this damage if the safe operation of the machine is no longer guaranteed.
  - Check that all nuts and bolts are properly secured.
  - Check the hydraulic components for damage and leaks and repair, if so required.
  - Check that all safety guards and all safety stickers are in place on the machine and are not damaged.
- The machine must **NEVER** be used without these.

The connection method is as follows: (Fig. 9)

1. Carefully reverse the tractor into a suitable position for connecting the tow bar to the tractor.
  - ⚠ **!! Ensure that that tractor is properly blocked and cannot move independently !!**
  - ⚠ **!! Switch the tractor engine off before getting off the tractor !!**
2. Change the height of the tow eye 5 of the desired height of the traction pin of the tractor.
  - 👉 **Important to adjust the height of the hitch so that the skid 6 hits the soil and still pressure on the hitch point of the tractor can be applied by cylinder 7.**
3. Connect the Vibra-Sandmaster to the tractor by placing the pin in the connector of the tractor through the towing hook of the Vibra-Sandmaster and securing this.
4. Connect the hydraulic hoses to the tractor.
5. Fit the camera screen in the tractor and connect it (see the manual of the camera system for operating and connection instructions).
6. Connect the PTO shaft between the Vibra-Sandmaster and the tractor (see section 5.1 for the correct length of the PTO shaft). Slip coupling to the machine side.
7. Rotate the height-adjustable leg 1 upward.
8. Start the tractor and activate the hydraulic output of the lifting machine and lift the machine.
9. Slide the supports 2 of the Verti-Quake in.
10. Remove the locking pin 3 on both sides of the machine, fit in hole 4 and secure with the corresponding clips.

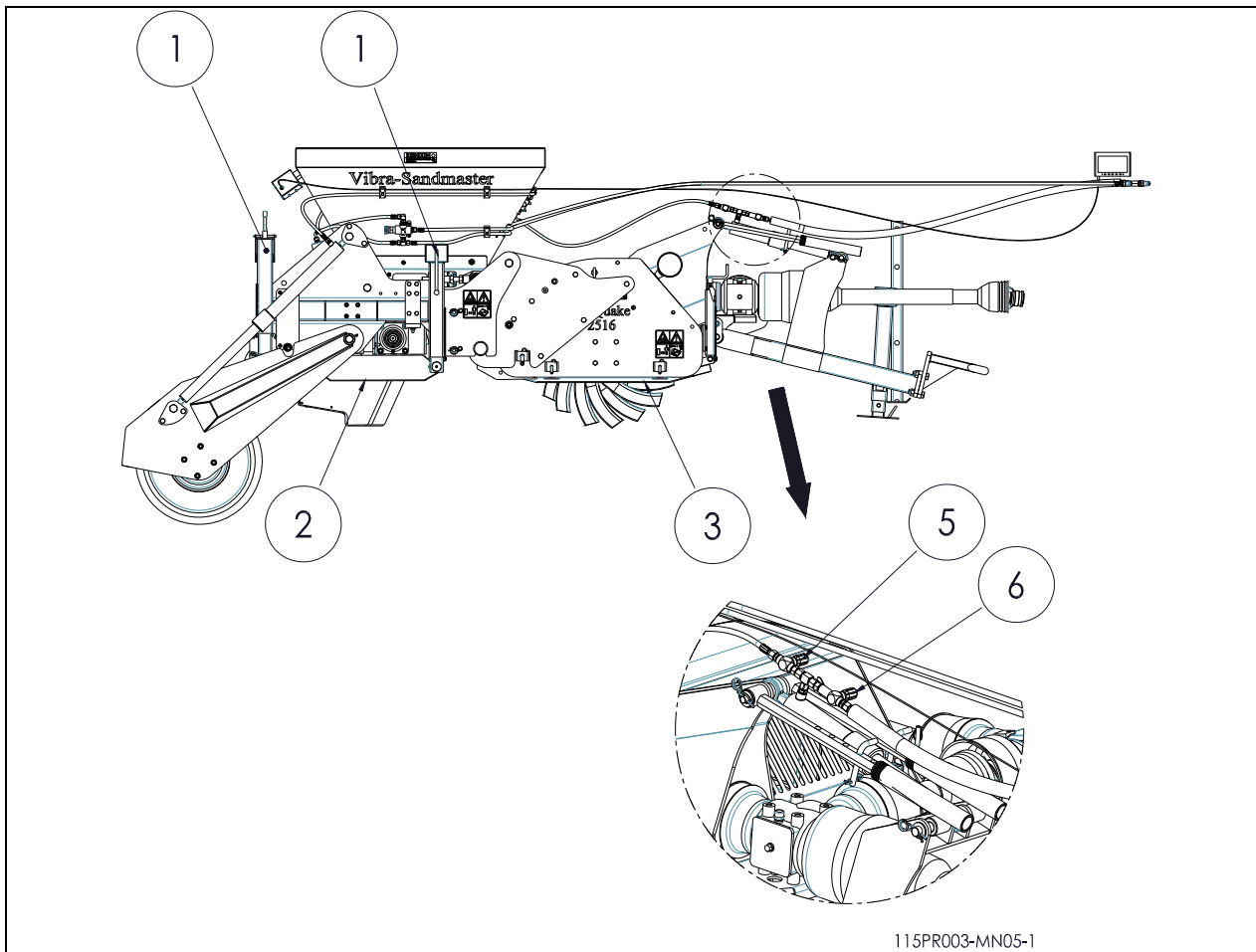

115PR003-MN05-1

Fig. 10

## 7.0 WORKING DEPTH ADJUSTMENT

(See fig.10)

1. If not yet connected, ensure that the Vibra-Sandmaster is connected to the tractor as described in section 6.0.
2. Start the tractor and activate the hydraulic output of the lifting machine and lift the machine.
  - ⚠ **!! Ensure that that tractor is properly blocked and cannot move independently !!**
  - ⚠ **!! Switch the tractor engine off before getting off the tractor !!**
3. Set the operating depth of the Verti-Quake (see the Verti-Quake manual for the procedure).
4. Set the operating depth of the Sandmaster approx. 25mm-40mm (1"-1.6") less deep than the operating depth of the Verti-Quake.  
You can do this by simultaneously rotating the spindles 1 at the front and rear.
  - 👉 **!! Ensure that the slider feet of the Sandmaster are parallel to the slider feet 3 of the Verti-Quake. This reduces the pressure of the machine on the floor and prevents damage to the surface !!**
5. Set the coulter pin to the desired depth (see section 7.2).



## 7.1 SETTING LIFTING / LOWERING ORDER

The Vibra-Sandmaster has a multi-tier lifting system (Fig.10).

The 1<sup>st</sup> part is located near the towing hook of the machine and makes it possible to lift the front of the machine (the Verti-Quake).

The 2<sup>nd</sup> part is located at the rear of the machine and operates the wheel set which makes it possible to lift the filling coulter/hopper section.

When starting machine operation, it is important that the Verti-Quake is lowered into the ground first so that it can pre-cut the grooves, after which the vibrating filling coulters follow.

The lowering order and speed can be set by rotating the chokes 5 (rear) and 6 (front).

Clockwise = slower Anti-clockwise = faster.

By opening up the choke at the front 6 further than the rear 5, the front will lower / lift sooner. The settings differ per circumstance and the right settings need to be found by trial and error.

Once the correct settings have been found, set the choke by means of the setscrew on the site of the adjustment button.



**!! WARNING! BE CAREFUL !!  
IF THE CHOKES ARE OPENED TOO FAR, THE MACHINE CAN LOWER VERY QUICKLY,  
CREATING AN UNSAFE SITUATION !!**

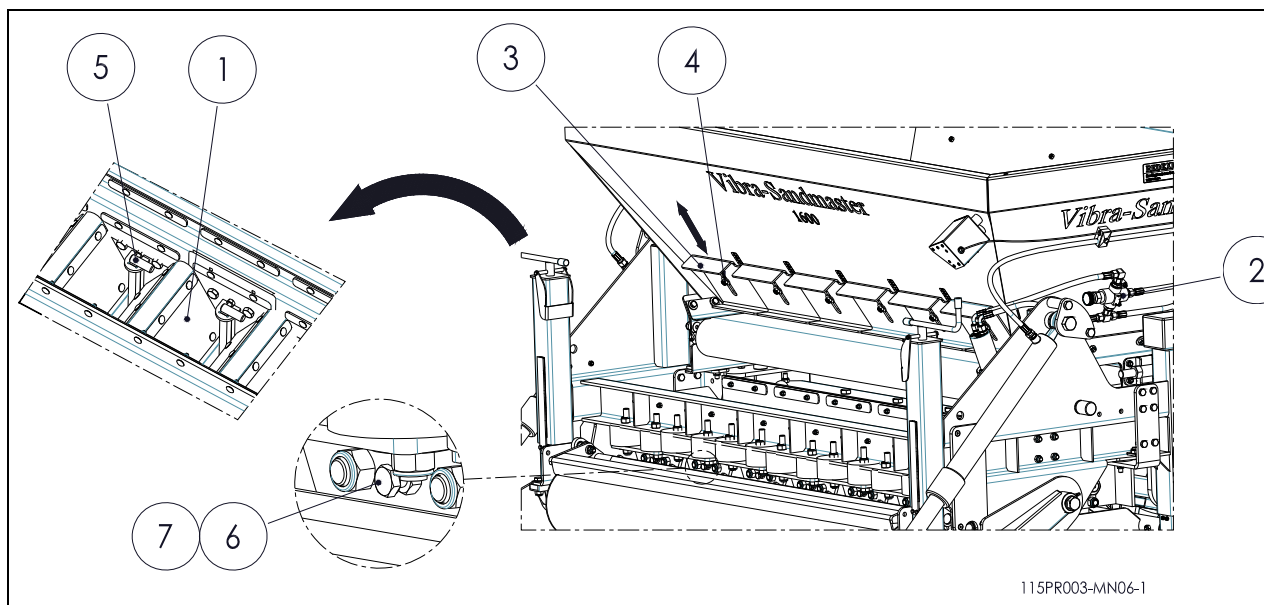

Fig.11

## 7.2 SETTING MATERIAL SUPPLY

The supply setting of the material that is fed to the grooves differs per type of material, operating depth, speed, etc.

Due to the combination of these factors, the correct setting for the material used is a process of trial and error.

Main point is that, when in operation, the filling coulters 1 must continue to be replenished without running empty. This can be monitored via the camera screen onboard the tractor.

In order to set the material supply on the machine, you can choose from the following options:

- **Setting by adjusting the speed of the conveyor.** (Fig.11)

The speed of the conveyor can be adjusted by rotating choke 2 at the side of the hopper. Clockwise = slower Anti-clockwise = faster.



**Practical experience shows that the supply can be controlled most effectively by switching on/off the conveyor as the filling funnels are running empty / full.**

- **Setting per filling coulter.** (Fig.11)

Per filling coulter, a dosing slide 3 is fitted at the rear of the hopper.

This dosing slide can be adjusted by loosening nuts 4, putting dosing slide 3 in the desired position and tightening nuts 4 again.



**Practical experience shows that the outer dosing slides must be opened further than the inner ones. In order to limit wear to the conveyor to a minimum, the slides must be opened as far as possible, with the position depending on the material.**

– **Setting of the coulter pin. (Fig.11)**

If the groove does not need to be fully filled, leaving an unfilled top part, or if the operating depth is not set at its maximum value, the coulter pin needs to be adjusted.

The procedure is as follows:

1. Unscrew contra nut 7 and unscrew bolt 6.
2. Adjust coulter pin 5.
3. Tighten bolt 6 and nut 7.

## **8.0 USING THE VIBRA-SANDMASTER**

The following checks must be made before proceeding to use the Vibra-Sandmaster at a site:

1. Are there any freestanding objects in the field? Remove them first.
2. Are there slopes? The Vibra-Sandmaster is only suitable for use on slopes with a maximum gradient of 20 degrees. Always work from the top to the bottom.
3. Are cables / pipes running in the ground? If so, establish their depth, and set the operating depth of the machine at a maximum of 60% of this value.
4. Does the ground contain any solid objects? Adjust the operating depth.
5. Are there any airborne objects in the area, such as golf balls, which will distract the user from the task at hand? If so, then the Vibra-Sandmaster may **NOT** be used.
6. Is there a hazard of sliding or subsiding? If so, postpone the use of the Vibra-Sandmaster.
7. If the surface is frozen or extremely wet; postpone activities until conditions improve.

## **9.0 OPERATING SPEED**

The effectiveness of the treatment is determined by the condition of the ground, speed and the rpm of the PTO.

When working with the Vibra-Sandmaster, the recommended speed is 0.5 to 1.5 km/h (0.3 – 0.9 mph) with a maximum PTO rpm of 540.

The speed and rpm of the PTO must be set on the basis of an educated assessment of the ground condition and the desired level of treatment.

## **10.0 TRANSPORTING THE VIBRA-SANDMASTER**

The user is responsible for transporting the Vibra-Sandmaster behind the tractor on public highways. Consult national legislation for the regulations.

The maximum speed across open fields, with the machine elevated, is 15 km/hour (9.3 mph), circumstances permitting, on account of the weight of the Vibra-Sandmaster. Driving at higher speeds constitutes a potential hazard for the driver / bystanders and may even cause damage to the machine.



**During transport, locking pins 4 at the rear of the machine must be insert and secured in hole 5.**

**In addition, at the front, pins 1 of stroke cylinders 3 must be inserted in the highest possible hole 6 (see Fig.12).**



**A minimum of 20% of the weight of the tractor must be supported on the front axle when the machine is elevated.**

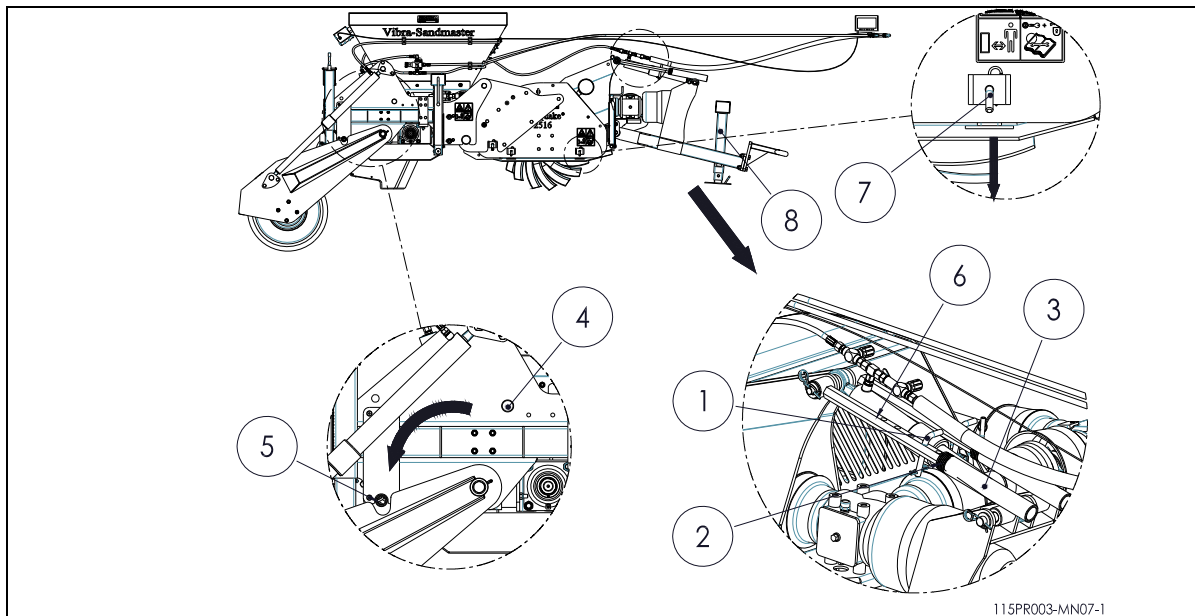

Fig.12

## 11.0 START / STOP PROCEDURE

The start procedure is **VERY** important. The Vibra-Sandmaster can get seriously damaged if this procedure is not executed as described below.

The start procedure is as follows:

1. Thoroughly inspect the Vibra-Sandmaster and check that all parts are working properly.



**!! If not, the problems must be rectified first before using the Vibra-Sandmaster !!**

2. Connect the Vibra-Sandmaster to the tractor (see section 6.0).
3. Fill the hopper with the supply material.
4. Drive to the site to be treated.
5. If so required, set the operating depth and material supply settings (see section 7.0-7.2).
6. Lower the machine until the blades nearly touch the surface.
7. Put the tractor into the correct gear with four-wheel drive engaged.
8. Increase tractor engine speed to approx. 1200 rpm and engage the PTO.
9. Increase the speed to  $\pm 300$  RPM
10. Put the tractor into motion and smoothly lower the Vibra-Sandmaster into the ground.
11. Increase PTO speed to a maximum of 540 rpm.
12. Engage the conveyor of the hopper by switching on the hydraulic output of the tractor. Drive a few metres forward, switch off the tractor and check the treated surface. Adjust the machine, if so required.
13. Adjust pin 1 with rings 2 of the stroke cylinders 3 so that the machine is resting on the slider feet level with the surface, yet still exercising some pressure on the towing hook.



**!! Ensure that that tractor is properly blocked and cannot move independently !!**

14. Once the setting is correct, restart the procedure and increase the speed to a maximum of 1.5 km/h (0.9 mph).



**Work in straight lines; bends inflict damage to the surface to be treated / machine.**



**Monitor material supply by means of the camera system and dose by switching on/off the hydraulic supply of the conveyor.**

Stopping takes place as follows:

1. Stop the conveyor by switching off the hydraulic output of the tractor.
2. Continue to drive until the filling funnels are empty.
3. Reduce the speed of the PTO to  $\pm 300$  rpm.
4. Gradually lift the Vibra-Sandmaster from the surface while driving.
5. Stop the PTO once the blades are out of the ground.
6. Proceed to the following site and repeat the procedure as described at the beginning of this section.



**!! NEVER engage the clutch of the tractor when operating the Vibra-Sandmaster. The Vibra-Sandmaster can push the tractor ahead at high speed !!**







**Working in accordance with the procedure above is paramount. Placing the machine in the ground with the PTO running may seriously damage the machine.**



**The Vibra-Sandmaster must be lowered into the ground CAREFULLY.**

## 12.0 DISCONNECTING THE VIBRA-SANDMASTER

The machine can be disconnected from the tractor in the following manner: (see Fig.12).

1. Drive the Vibra-Sandmaster to a storage area with a stable / level surface.
  -  **!! Ensure that that tractor is properly blocked and cannot move independently !!**
  -  **!! Switch the tractor engine off before getting off the tractor !!**
2. Remove the pins 7, lower the supports of the Verti-Quake and secure them with pins 7 and corresponding locking pins (both sides of the machine).
3. If not yet done, insert locking pins 4 at the rear of the machine in hole 5 and secure them with the locking pins.
4. Remove pins 1 of the stroke cylinders 3 from the highest possible hole 6.
5. Carefully lower the Vibra-Sandmaster on the surface by activating the hydraulic output of the lifting mechanism.
  -  **!! Ensure that the Vibra-Sandmaster is resting stable on the surface prior to dismantling the tractor !!**
6. Rotate support 8 downward and disconnect the hitch from the tractor.
7. Disconnect the PTO.
8. Disconnect the hydraulic tubes.
9. Disconnect the camera screen in the tractor.
  -  **!! Ensure that the Vibra-Sandmaster<sup>®</sup> is in a stable position !!**
10. Start the tractor and drive away.

## 13.0 TROUBLESHOOTING

<b>Problem</b>	<b>Possible cause</b>	<b>Solution</b>
Too much damage to the surface to be treated.	<ul style="list-style-type: none"> <li>– Blades are bent / damaged.</li> <li>– Not driven in a straight line.</li> <li>– Soil is too wet.</li> <li>– Machine depth setting is too deep.</li> </ul>	<ul style="list-style-type: none"> <li>– Align blades. Fit new blades.</li> <li>– Try and drive in a straight line.</li> <li>– Postpone the work until the soil is sufficiently dry.</li> <li>– Decrease depth setting on machine (see section 7.0).</li> </ul>
The vibrating filling funnels do not work.	<ul style="list-style-type: none"> <li>– The PTO slip coupling is slipping.</li> <li>– Gearbox is damaged.</li> </ul>	<ul style="list-style-type: none"> <li>– Check the PTO slip coupling (see also section 5.3).</li> <li>– Repair or replace the gearbox.</li> </ul>
Cam coupling (Verti-Quake / slip coupling of the PTO races too often.	<ul style="list-style-type: none"> <li>– Cam coupling is worn.</li> <li>– Clip coupling is worn.</li> <li>– Too many stones.</li> <li>– Surface too hard.</li> <li>– Speed too high.</li> <li>– PTO rpm too low.</li> </ul>	<ul style="list-style-type: none"> <li>– Replace cam coupling.</li> <li>– Adjust or replace the slip coupling (see also section 5.0).</li> <li>– Adjust operational depth.</li> <li>– Adjust operational depth.</li> <li>– Adjust speed.</li> <li>– Increase PTO rpm.</li> </ul>
Machine wants to push tractor forward.	<ul style="list-style-type: none"> <li>– Tractor too light.</li> <li>– No four-wheel drive.</li> <li>– Tractor slips due to insufficient pressure on the towing hook.</li> </ul>	<ul style="list-style-type: none"> <li>– Increase weight of tractor or select a different one.</li> <li>– Engage four-wheel drive.</li> <li>– Put pressure on the towing hook by adjusting the pins of the stroke cylinders (see point 13 of section 11.0).</li> </ul>
Grooves not sufficiently filled.	<ul style="list-style-type: none"> <li>– Driven too fast.</li> <li>– Filling coulter not full with sand.</li> <li>– Coulter pins set too deep.</li> <li>– Filling material too sticky.</li> </ul>	<ul style="list-style-type: none"> <li>– Drive slower.</li> <li>– Engage the conveyor more frequently.</li> <li>– Adjust the coulter pins (see section 7.2).</li> <li>– Use drier or alternative material.</li> </ul>
Conveyor not running.	<ul style="list-style-type: none"> <li>– Conveyor driving pulley slipping.</li> <li>– Choke is closed.</li> <li>– Hydraulic motor faulty.</li> </ul>	<ul style="list-style-type: none"> <li>– Tension the conveyor (see section 14.3).</li> <li>– Adjust choke (see section 7.2).</li> <li>– Repair or replace the hydraulic motor.</li> </ul>
Blades dig up too much soil.	<ul style="list-style-type: none"> <li>– Blades are bent.</li> <li>– Soil is too wet.</li> </ul>	<ul style="list-style-type: none"> <li>– Align knives. Fit new blades.</li> <li>– Postpone the work until the soil is drier.</li> </ul>

# 14.0 LUBRICATING POINTS

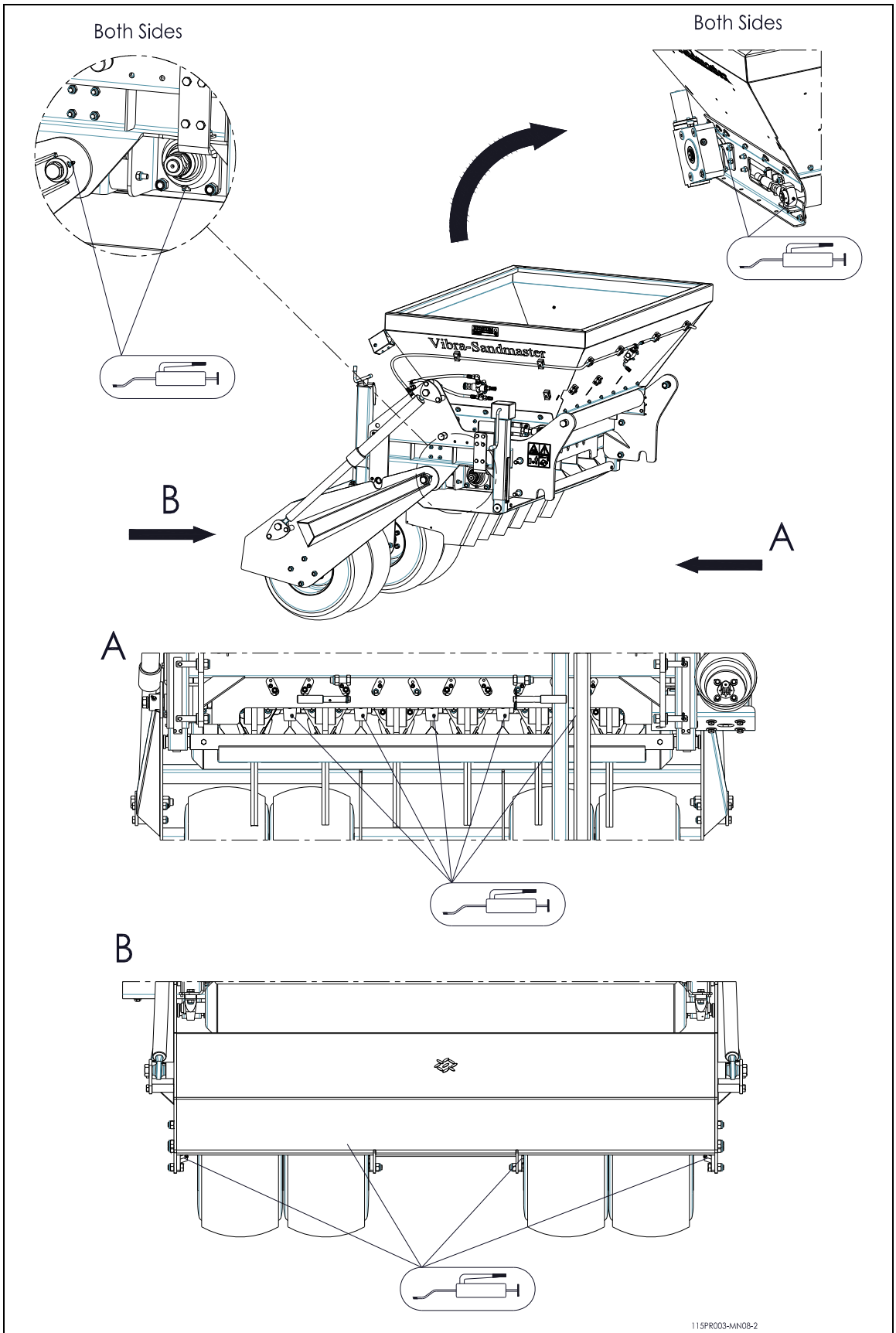

Fig.13

## 14.1 MAINTENANCE

Adjustments and repairs to the Vibra-Sandmaster must be performed by authorised, technical staff only.

Only use original Vibra-Sandmaster parts for maintenance or repairs so as to guarantee the safety of the machine and user.

See the Verti-Quake manual for maintenance on this device.

<b>Time schedule / frequency</b>	<b>Checkpoint / Lubrication point</b>	<b>Method</b>
Prior to <b>each</b> use	<ul style="list-style-type: none"> <li>- Check for loose bolts / nuts.</li> <li>- Presence and legibility of the safety stickers (Fig. 5).</li> <li>- Check for any damage to the hydraulic components.</li> <li>- Check the tyre pressure.</li> <li>- Check the roller bearings and the drive line and grease all lubricating points.</li> </ul>	<ul style="list-style-type: none"> <li>- Tighten the loose nuts / bolts.</li> <li>- Replace if not present / damaged.</li> <li>- Repair or replace, if so required.</li> <li>- 0.8-1.8 bar (11.6-26 PSI)</li> <li>- 1-2 shots High Grade Grease HT Q9 Replace if necessary.</li> </ul>
After <b>every</b> use	<ul style="list-style-type: none"> <li>- Clean the machine.</li> </ul>	<ul style="list-style-type: none"> <li>- Caution required with the bearings if a high pressure washer is used.</li> </ul>
After the <b>first</b> 20 operational hours (new or repaired)	<ul style="list-style-type: none"> <li>- Grease all lubricating points (see section 13.0).</li> <li>- Check the roller bearings and the drive line.</li> <li>- Check for any damage to the hydraulic components.</li> <li>- Check for loose bolts / nuts.</li> </ul>	<ul style="list-style-type: none"> <li>- 1-2 shots EP2 + High Grade Grease HT Q9</li> <li>- Check and replace if necessary.</li> <li>- Repair or replace, if so required.</li> <li>- Tighten the loose nuts / bolts.</li> </ul>
After <b>every</b> 80 operation hours or annually	<ul style="list-style-type: none"> <li>- Check the roller bearings and the drive line and grease all lubricating points.</li> <li>- Check for loose bolts / nuts.</li> <li>- Check the hydraulic components are working properly and for any damage.</li> <li>- Check the tension of conveyor.</li> <li>- Check the gearboxes and the oil level in the gearboxes.</li> <li>- Check and lubricate the PTO shafts.</li> </ul>	<ul style="list-style-type: none"> <li>- 1-2 shots High Grade Grease HT Q9 Replace if necessary.</li> <li>- Tighten the loose nuts / bolts.</li> <li>- Check and replace if necessary.</li> <li>- Tension, if so required (see section 13.3).</li> <li>- See the parts manual for oil specifications and volume.</li> <li>- 1-2 shots EP2.</li> </ul>
After <b>every</b> 500 operational hours	<ul style="list-style-type: none"> <li>- Replace the oil in the gearboxes.</li> </ul>	<ul style="list-style-type: none"> <li>- See the parts manual for oil specifications and volume.</li> </ul>



## 14.2 REPLACING THE FILLING COULTERS

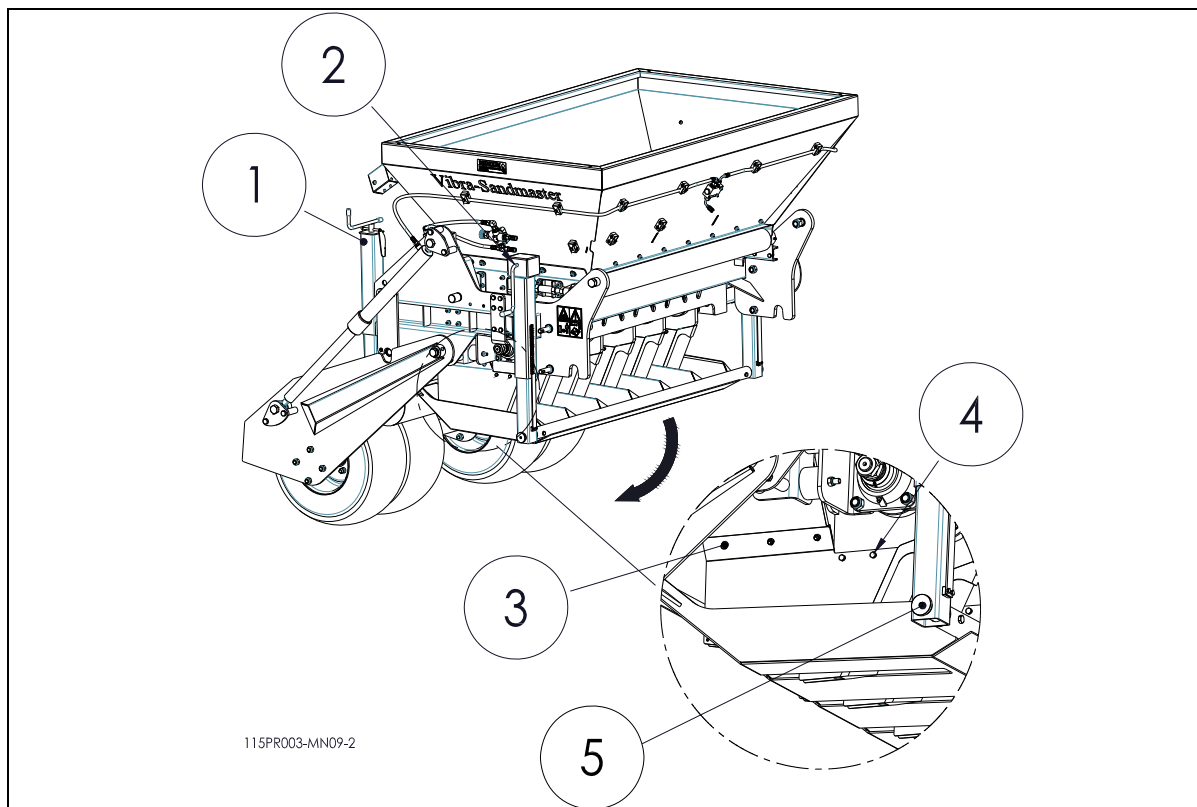



Fig.14

Follow the procedure below when fitting new or different filling coulters  
(See Fig. 14):

1.  **!! Ensure that the Vibra-Sandmaster is stable on the floor and that it cannot subside or slide !!**
2. Rotate the slider feet downward by unscrewing spindles 1 and 2 on either side of the machine.
3. Remove pin 5 on both ends of the machine and let the slider feet rotate downwards.
4. Remove the bolts 3 and nuts 4.
5. Remove the filling coulters to be replaced.  
 **!! Take care! The blades are sharp !!**
6. Fit the new filling coulters
7. Fit the bolts 3 and nuts 4 and firmly tighten them.
8. Connect the slider feet with pin 5 on both sides of the machine.



**At the same time, check the drive mechanism of the filling coulters and lubricate the bearings (for lubricating points see section 14.0)**

## 14.3 RETENSIONING THE CONVEYOR

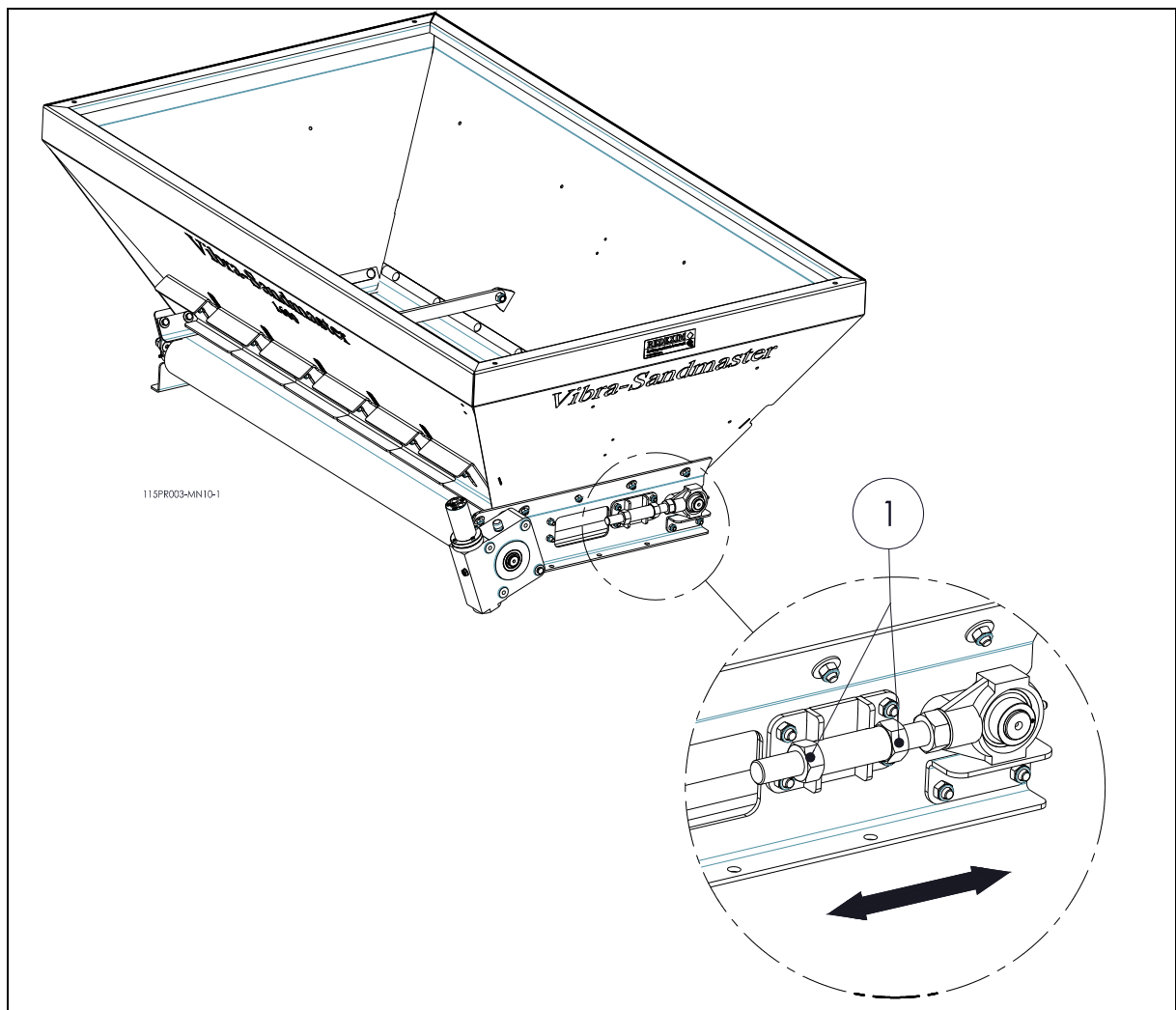

Fig.15

If the conveyor of the hopper starts slipping and does not transport the material properly, it needs retensioning.

The procedure is as follows: (see Fig.11)



**!! Ensure that the Vibra-Sandmaster is stable on the floor and that it cannot subside or slide !!**

1. Unscrew the nuts 1.
2. Adjust the roller by tightening or loosening the nuts 1.
3. Adjust the roller on the other side of the hopper by the same margin.
4. If the correct tension has been reached, firmly tighten the nuts 1 again.
5. Switch on the conveyor and check whether it runs smoothly and centred. Readjust the conveyor, if so required.



**!! Overtension in the conveyor will shorten its lifespan !!**