



– RELIABLE
WOOD
CHIPPING

TP 100 PTO TP 100 MOBILE

TECH SHEET

EFFICIENT DRUM CHIPPER



DESIGNED

MANUFACTURED

DENMARK



TP 100 PTO

EFFICIENT DRUM CHIPPER

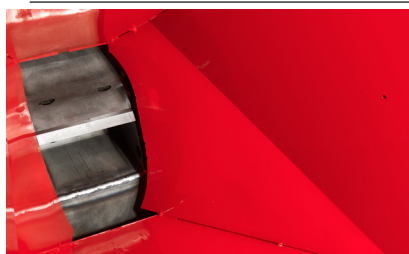

SMALL AND COMPACT

- The TP 100 PTO is a sturdy drum chopper with a vertical hopper with safety flap
- 2 reversible knives
- 1 reversible steel in wear-resistant steel

WE STAND BY OUR PRODUCTS

- 3-year (or 1000 hours) TP WARRANTY
- Includes engine and drum
- Wear parts not included

AVOID DOWN-TIME WITH TP SERVICE BOX

- TP SERVICE BOX with critical wear parts is available as an option
- Includes an extra set of knives, counter steel

SERVICE FRIENDLY LIKE NO OTHER

- The keep it simple machine construction not only has aesthetic benefits.
- Large clean surfaces that effectively protect the machine components,
- Provide a quick and easy access to daily maintenance, including the lubrication points.
- No need for special tools



100 mm



15 hp/40 hp



4-20 mm



195 kg

TP 100 MOBILE

EFFICIENT DRUM CHIPPER



Handle (adjustable)



2 in 1 support foot (adjustable)



EFFECTIVE AND STRONG

- Compact machine that does not take up much space.
- For branches and smaller trees up to 10cm
- Width only 74 cm
- Weight 240 kg



VANGUARD EFI18 HP

- 2-cylinder air-cooled petrol engine with electronic ignition system
- Low consumption
- Cheap to maintain
- Large petrol tank - 8,5 litres
- E-start comes as standard



AVOID DOWN-TIME WITH TP SERVICE BOX

- TP SERVICE BOX with critical wear parts is available as an option
- Includes an extra set of knives, counter steel, elts, engine filters, bolts and nuts.



TP MOVER

- 24V Infinite electric motor - up to 6 km/h
- For versatile use in terrain
- Suitable for trailer ramps
- Power switch

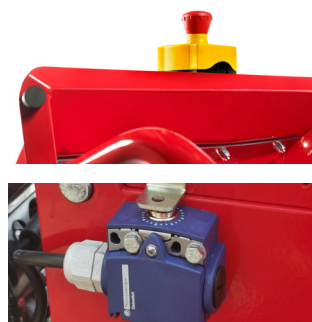

USER SAFETY

- Emergency stop switch stops the engine is located on top of the funnel
- The safety switch prevents engine start-up



100 mm



18 hp



5 - 20 mm



240 kg

TP 100 PTO/MOBILE

EFFICIENT DRUM CHIPPER

WOOD CHIPPER	TP 100 PTO	TP 100 MOBILE
Max. wood diameter	100 mm	100 mm
Roller opening	H x W = 150 x 275 mm	H x W = 150 x 275 mm
Chipping principle	Drum	Drum
In feed angle	Parallel to driving direction	Parallel to driving direction
Feed rollers	No	No
Drum diameter	410 mm	410 mm
Drum weight	48 kg	48 kg
Number of knives	2 (reversible)	2 (reversible)
Counter steel	1 (reversible)	2 (reversible)
Power requirement min.-max.	15 - 40 hp	-
Engine power	-	18 hp / 13 kW
Torque	-	35 Nm
Engine	-	B&S Vanguard
Cylindre	-	2
Tankcapacity	-	8,5 liter (petrol)
Fuelconsumption	-	3 l/o
Capacity/hour	7 m ³ /o	3 m ³ /o
Weight	195 kg	240 kg
Height	1580 mm	1734 mm
Wide	1515 mm	736 mm
Length	791 mm	2335 mm

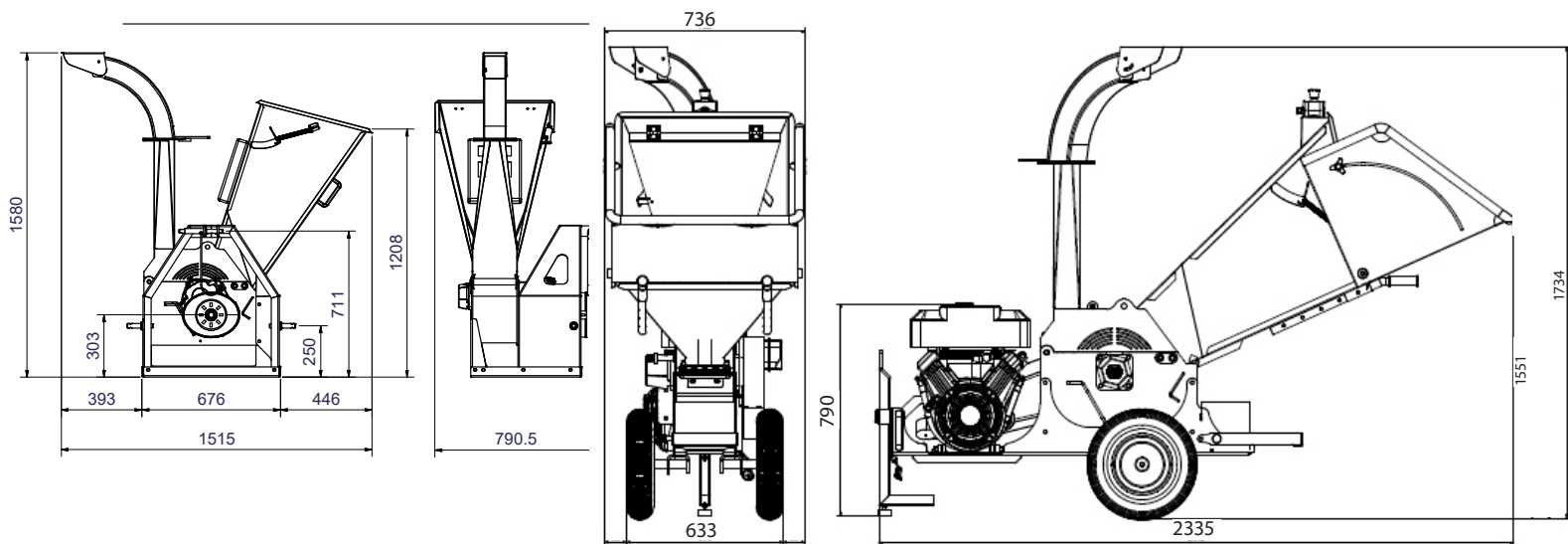

LINDDANA A/S

Linddana A/S
Ølholm Bygade 70
DK-7160 Tørring

T +45 75 80 52 00
tp@linddana.com
www.linddana.com